

2009 OTC Research Project Report

Optimal Loop Placement and Models for Length-based Vehicle Classification and Stop-and-Go Traffic

Submitted by

Heng Wei, Ph.D., P.E.
Associate Professor, School of Advanced School
Director, ART-Engines Transportation Research Laboratory
College of Engineering and Applied Science
University of Cincinnati, 792 Rhodes Hall
Cincinnati, OH 45221-0071
Tel: 513-556-3781; Fax: 513-556-2599
Email: heng.wei@uc.edu



Submitted to:

Ohio Transportation Consortium (OTC)
The University of Akron
Akron, OH 44325-6106



Draft: September 2010
Update: January 2011

This Report is prepared by

Principle Investigator:

Heng Wei, Ph.D., P.E.,
Associate Professor
School of Advanced School
Director, ART-Engines Transportation Research Laboratory
College of Engineering and Applied Science
University of Cincinnati, 792 Rhodes Hall, Cincinnati, OH 45221-0071
Tel: 513-556-3781; Fax: 513-556-2599
Email: heng.wei@uc.edu

Project Researcher:

Qingyi Ai
Ph.D. Candidate, School of Advanced School
Research Assistant, ART-Engines Transportation Research Laboratory
College of Engineering & Applied Science
University of Cincinnati, 735 ERC, Cincinnati, Ohio 45221-0071
Tel: 513-708-8928
E-mail: aiqi@email.uc.edu

Co-Principle Investigator:

Deogratias Eustace, Ph.D., P.E., PTOE
Assistant Professor
Dept of Civil & Environmental Engineering & Engineering Mechanics
University of Dayton, 300 College Park, Dayton, OH 45469-0243
Tel: (937) 229-2984
Email: deo.eustace@udayton.edu

Co-Principle Investigator:

Ping Yi, Ph.D., P.E.,
Professor, Civil Engineering
The University of Akron
Auburn Science & Engineering Center Rm 213
Akron, OH 44325-6106
Tel: 330-972-7294; Fax: 330-972-5449
Email: pyi@uakron.edu

DISCLAIMER

The contents of this report reflect the views of the authors, who are responsible for the facts and the accuracy of the information presented herein. This document is disseminated under the sponsorship of the Department of Transportation University Transportation Centers Program, in the interest of information exchange. The U.S. Government assumes no liability for the contents or use thereof.

ACKNOWLEDGEMENT

The authors would like to thank Mr. Sudhir Reddy Itekyala, M.S. student in the Advanced Research in Transportation Engineering and Systems (ART-Engines) laboratory at the University of Cincinnati (UC), who assisted greatly in video data collection, vehicle trajectory data extraction, and modeling efforts on this project. The authors also would like to thank Dr. Ben Coifman at the Ohio State University, who offered great assistance by providing the event dual-loop data of the study sites. Mr. Zhixia Li and Mr. Zhuo Yao, the Ph.D. students at UC also provided great help in VEVID update and data collection, respectively. Special gratitude goes to them for their strong supports.

SUMMARY

Inductive loops are widely used nationwide for traffic monitoring as a data source for a variety of needs in generating traffic information for operation and planning analysis, validations of travel demand models, freight studies, pavement design, and even emission impact analysis of traffic operation. The loop data have also been used for vehicle length-based classification in many states including Ohio. The dual-loop detector consists of two single loop detectors which are placed apart at a fixed short distance, and this configuration enables the dual-loop detector data a potential real-time data source for speed and vehicle classifications. However, the existing dual-loop length-based vehicle classification model has been well evaluated against free traffic but not suitable for non-free traffic conditions (such as synchronized and stop-and-go congestion states). This project is there motivated to identify the performance of the existing length-based vehicle classification models under various traffic conditions, and develop new models against congested traffic using dual-loop data.

In order to evaluate the existing models against different traffic flows, namely free flow, synchronized flow and stop-and-go flow, the concurrent ground-truth video data is employed and the software VEVID is used to extracted vehicle trajectory data from the video. This extracted vehicle trajectory data is used to compare with the event dual-loop data and to evaluate the existing vehicle classification models. As a result, the existing model is proven capable of estimating the vehicle length very well under free flow; however, large errors are identified within both synchronized and stop-and-go traffic streams. New length-based vehicle classification models, i.e., VC-Sync model and VC-Stog model are developed for cases of synchronized traffic flow and stop-and-go traffic, respectively. Comparing to the ground-truth data, the error of the estimated length by the VC-Sync model is reduced to 8.5% compared to 35.2% produced by the existing model, and the error of the VC-Stog model is reduced to 27.7% compared to 210% generated by the existing model.

In order to ensure the right use of the above models under different traffic conditions, correct identification of varied traffic flow states is a critical need. For this purpose, an algorithm for identifying three traffic states, namely, free flow, synchronized flow, and stop-and-go flow, has been developed. A heuristic approach is employed for developing this algorithm with combination of occupancy and speed which are directly resulted from the dual-loop data. Thresholds of variables involved in the algorithm are recommended based on the statistical analysis of the data gained from the sampling dual-loop stations in I-71/I70 in Columbus, Ohio.

In addition, loop standards of layout and installation method have been collected from 17 states in the United States. Brief analysis of the collected standards is conducted to provide fundamental information for future evaluation. Based on the detailed provided information, it may be concluded that there are no substantial differences in their standards and the most commonly used loop detectors are 6' × 6' square and 6' × 50' rectangular loops. The NEMA

(National Electrical Manufacturers Association) inductive loop detectors have been widely used in the US.

This report is organized as follows: Chapters 1 through 3 and Chapter 6 are prepared by Dr. Heng Wei and Mr. Qingyi Ai, University of Cincinnati; Chapter 4 is prepared by Dr. Deogratias Eustace, University of Dayton; and Chapter 5 is prepared by Dr. Ping Yi, University of Akron.

TABLE OF CONTENTS

DISCLAIMER	i
ACKNOWLEDGEMENT	ii
SUMMARY	iii
TABLE OF CONTENTS	v
LIST OF FIGURES	vii
LIST OF TABLES	viii
CHAPTER 1: INTRODUCTION	1
1.1 BACKGROUND	1
1.2 IDENTIFIED PROBLEMS	2
1.3 GOAL AND OBJECTIVES	2
CHAPTER 2: LITERATURE REVIEW	4
2.1 DUAL-LOOP DATA PROBLEMS.....	4
2.2 LENGTH-BASED VEHICLE CLASSIFICATION USING DUAL-LOOP DATA.....	4
2.3 TRAFFIC FLOW CHARACTERISTICS.....	5
2.4 THRESHOLDS FOR DISTINGUISHING TRAFFIC STATES	6
CHAPTER 3: VEHICLE CLASSIFICATION UNDER DIFFERENT TRAFFIC STATES	9
3.1 STUDY SITES.....	10
3.2 DATA COLLECTION	11
3.2.1 <i>Video Data Collection</i>	11
3.2.2 <i>Event Dual-loop Data Collection</i>	12
3.2.3 <i>GPS Data Collection</i>	13
3.3 VIDEO TRAJECTORY DATA EXTRACTION.....	14
3.3.1 <i>Introduction of VEVID</i>	14
3.3.2 <i>Setting Up Field Reference Points for VEVID</i>	15
3.3.3 <i>Vehicle Trajectory Data Extraction</i>	17
3.4 DUAL-LOOP DATA PROCESSING.....	17
3.4.1 <i>Existing Problems in the Original Event Dual-loop Data</i>	17
3.4.2 <i>Algorithms of Original Event Dual-loop Data Processing</i>	18
3.4.3 <i>Loop Sensitivity Analysis</i>	19
3.5 TRAFFIC STATES IDENTIFICATION ALGORITHM	21
3.5.1 <i>Free Flow Identification</i>	21
3.5.2 <i>Synchronized traffic identification</i>	24
3.5.3 <i>Stop-and-go traffic identification</i>	24
3.6 EVALUATING THE EXISTING VEHICLE CLASSIFICATION MODEL.....	25
3.7 DEVELOPING NEW VEHICLE CLASSIFICATION MODEL UNDER SYNCHRONIZED FLOW	25
3.8 DEVELOPING NEW VEHICLE CLASSIFICATION MODEL UNDER STOP-AND-GO TRAFFIC	28
3.8.1 <i>Scenarios of Vehicle Stopping Status</i>	28
3.8.2 <i>Developing Length-based Vehicle Classification against Stop-and-Go Traffic</i>	29

CHAPTER 4: LOOP DETECTOR LAYOUTS ADOPTED BY VARIOUS STATE DOTS.....	33
4.1 STATE OF CALIFORNIA.....	33
4.1.1 <i>Specification</i>	33
4.1.2 <i>Automatic Vehicle Classification Station</i>	34
4.2 STATE OF CONNECTICUT.....	35
4.2.1 <i>Functional Requirements</i>	35
4.2.3 <i>Electrical Requirements</i>	35
4.2.4 <i>Mechanical Requirements</i>	36
4.2.5 <i>Delay Operation</i>	36
4.2.6 <i>Extended Operations</i>	36
4.2.7 <i>Loop Detector Saw Cut</i>	36
4.3 STATE OF FLORIDA.....	37
4.3.1 <i>Materials</i>	37
4.3.2 <i>Installation Requirements</i>	37
4.4 STATE OF ILLINOIS.....	40
4.5 STATE OF INDIANA.....	42
4.6 STATE OF MARYLAND.....	44
4.7 STATE OF MASSACHUSETTS.....	46
4.8 STATE OF MICHIGAN.....	48
4.9 STATE OF MISSISSIPPI.....	48
4.10 STATE OF MONTANA.....	50
4.11 STATE OF NEW JERSEY.....	50
4.12 STATE OF NEW YORK.....	51
4.13 STATE OF OREGON.....	52
4.14 STATE OF PENNSYLVANIA.....	53
4.15 STATE OF TEXAS.....	55
4.16 STATE OF UTAH.....	57
4.17 STATE OF WASHINGTON.....	58
CHAPTER 5: TRAVEL TIME ESTIMATE BY LOOP DATA	60
5.1 EXTRAPOLATION METHODS.....	60
5.1.1 <i>Half-Distance Approach</i>	60
5.1.2 <i>Average Speed Approach</i>	60
5.1.3 <i>Minimum Speed Approach</i>	61
5.2 STATISTICAL METHODS.....	61
5.3 THEORETICAL METHODS.....	61
CHAPTER 6: CONCLUSIONS AND RECOMMENDATIONS.....	62
REFERENCES.....	63

LIST OF FIGURES

FIGURE 1. SKETCH OF DUAL-LOOP DETECTOR STATION.....	1
FIGURE 2. DEMONSTRATIONS OF THREE TRAFFIC PATTERNS (KERNER ET AL.).....	6
FIGURE 3. FRAMEWORK OF EVALUATING DUAL-LOOP DATA BASED VEHICLE CLASSIFICATION MODELS ..	9
FIGURE 4. LOOP STATION V1002 ON I-70/71 IN DOWNTOWN COLUMBUS, OH	11
FIGURE 5. LOOP STATION V1003 ON I-70/71 IN DOWNTOWN COLUMBUS, OH	11
FIGURE 6. VIDEOTAPING AT THE SELECTED DUAL-LOOP STATION.....	11
FIGURE 7. ILLUSTRATION OF VIDEO DATA COLLECTION AT A SELECTED STUDY SITE	12
FIGURE 8. THE GPS DATA LOGGER AND THE INTERFACE OF ITS SOFTWARE.....	14
FIGURE 9. SETTING UP REFERENCE POINTS MANUALLY (DISTANCE BETWEEN POINTS: 20FT)	15
FIGURE 10. PROCEDURE FOR SETTING REFERENCE POINTS USING VPC-GPS APPROACH.....	16
FIGURE 11. REFERENCE POINTS SET IN VEVID USING VPC-GPS APPROACH	16
FIGURE 12. ALGORITHM OF REMOVING DATA ERRORS CAUSED BY VEHICLE LANE-CHANGING	19
FIGURE 13. SKETCH OF DUAL-LOOP SENSITIVITY ANALYSIS	20
FIGURE 14. THE FLOWCHART OF SENSITIVITY ANALYSIS.....	20
FIGURE 15. TRAFFIC SPEED, OCCUPANCY, AND VOLUME UNDER DIFFERENT TRAFFIC STATES.....	22
FIGURE 16. SPEED DISTRIBUTIONS IN DIFFERENT LANES	23
FIGURE 17. A FLOWCHART OF IDENTIFYING TRAFFIC STATES.....	25
FIGURE 18. ESTIMATED VEHICLE LENGTHS UNDER SYNCHRONIZED TRAFFIC.....	26
FIGURE 19. DIFFERENT SCENARIOS OF VEHICLE STOPPING ON LOOPS UNDER STOP-AND-GO FLOW	29
FIGURE 20. A FLOWCHART FOR IDENTIFYING VEHICLE STOPPING STATUS	31
FIGURE 21. ESTIMATED VEHICLE LENGTHS UNDER STOP-AND-GO TRAFFIC.....	31
FIGURE 22. ADVANCE AND MID LOOP DETECTORS.....	33
FIGURE 23. PIEZO-ELECTRIC SENSORS.....	34
FIGURE 24. FLORIDA STANDARD VEHICLE LOOP INSTALLATION DETAILS	39
FIGURE 25. IDOT TYPICAL LAYOUT FOR DETECTION LOOPS.....	40
FIGURE 26. IDOT TYPICAL LAYOUT FOR DETECTION LOOPS.....	41
FIGURE 27. IDOT’S DETECTOR LOOP INSTALLATION DETAILS	41
FIGURE 28. INDOT LOOP WIRING DIAGRAM	42
FIGURE 29. A TYPICAL LOOP SAW-CUT DETAIL	43
FIGURE 30. INDOT TYPICAL TRAFFIC LOOP DETECTOR STANDARDS FOR ONE LANE	44
FIGURE 31. INDOT TYPICAL TRAFFIC LOOP DETECTOR STANDARDS FOR TWO LANES.....	44
FIGURE 32. MDOT ATR LOOP DETECTOR LAYOUT STANDARDS (TYPE I).....	45
FIGURE 33. MDOT ATR LOOP DETECTOR LAYOUT STANDARDS (TYPE II)	45
FIGURE 34. MHD PLAN SHOWING ARRANGEMENTS OF LOOP DETECTORS FOR TRAFFIC DATA COLLECTION STATIONS.....	47
FIGURE 35. TYPICAL LOOP DETECTORS ARRANGEMENTS FOR MDOT SIGNALIZED INTERSECTIONS	48
FIGURE 36. MDOT’S LOOP DETECTOR INSTALLATION DETAILS FOR LARGE DETECTOR	49

FIGURE 37. MDOT’S LOOP DETECTOR INSTALLATION DETAILS FOR SMALL DETECTOR	49
FIGURE 38. NJDOT’S TYPICAL LOOP DETECTOR INSTALLATION	50
FIGURE 39. NJDOT’S LOOP CONFIGURATIONS.....	50
FIGURE 40. LOOP DETECTOR ARRANGEMENTS AT A TYPICAL 4-LANE COUNT STATION IN NY	51
FIGURE 41. TYPICAL LOOP DETECTORS USED BY PENNDOT	54
FIGURE 42. A TYPICAL LOOP DETECTOR FOR AN ENHANCED BICYCLE AND MOTORCYCLE DETECTION..	55
FIGURE 43. TYPICAL LOOP DETECTOR LAYOUTS USED IN TEXAS.....	55
FIGURE 44. TYPICAL LOOP DETECTOR LAYOUTS USED IN TEXAS.....	56
FIGURE 45. A TYPICAL LOOP SAW CUT CROSS-SECTION PER TEXAS STANDARDS.....	56
FIGURE 46. TEXAS STANDARDS FOR LOOP DETECTOR PLACEMENT DETAILS.....	57
FIGURE 47. TYPICAL LOOP DETECTORS USED IN UTAH HIGHWAYS	58
FIGURE 48. TYPICAL LOOP DETECTORS USED BY WASHINGTON DOT.....	59
FIGURE 49. FIGURE ILLUSTRATING THE EXTRAPOLATION METHODS	60

LIST OF TABLES

TABLE 1. SUMMARY OF THRESHOLDS OF TRAFFIC STATES USED IN PREVIOUS STUDIES.....	8
TABLE 2. EXEMPLARY SAMPLE OF THE EVENT DUAL-LOOP DATA	13
TABLE 3. EXEMPLARY SAMPLE OF GPS DATA IMPORTED INTO EXCEL FILE.....	13
TABLE 4. SAMPLE DATA EXTRACTED FROM VIDEO USING VEVID.....	17
TABLE 5. TIMESTAMPS OF THE M LOOP AND THE S LOOP	18
TABLE 6. VEHICLE ASSIGNMENT DURING SYNCHRONIZED TRAFFIC (3-BIN SCHEME).....	27
TABLE 7. VEHICLE ASSIGNMENT DURING SYNCHRONIZED TRAFFIC (4-BINS SCHEME).....	27
TABLE 8. VEHICLE ASSIGNMENT DURING STOP-AND-GO TRAFFIC (3-BIN SCHEME).....	32
TABLE 9. CALIFORNIA’S SPEED AND LOOP DISTANCE FOR ADVANCE DETECTION GUIDELINES	34
TABLE 10. ODOT’S RECOMMENDED LOOP SPACING.....	52

CHAPTER 1: INTRODUCTION

1.1 Background

Inductive loops are widely used nationwide for traffic monitoring as a data source for a variety of needs in generating traffic information for operation and planning analysis, validation of travel demand models, freight management study, pavement design, and even emission impact analysis of traffic operation. The loop data has also been used for vehicle length-based classification in many states, including Ohio (Ohio Department of Transportation 2007). There are two typical types of inductive detectors: single loop and dual loop. Although lots of efforts have been reported on estimating vehicle speed and vehicle length by using single loop data (Coifman and Kim 2008, Zhang et al. 2008, and Zhu et al. 2010), the structure of the single loop limits the accuracy. The dual-loop detector consists of two single loop detectors which are placed apart at a fixed short distance (e.g. 20 ft) (Figure 1). This configuration enables the dual-loop detector data more applicable to estimating the vehicle speed and vehicle length. Such a capability makes dual-loop detectors a potential real-time data source for vehicle classifications.

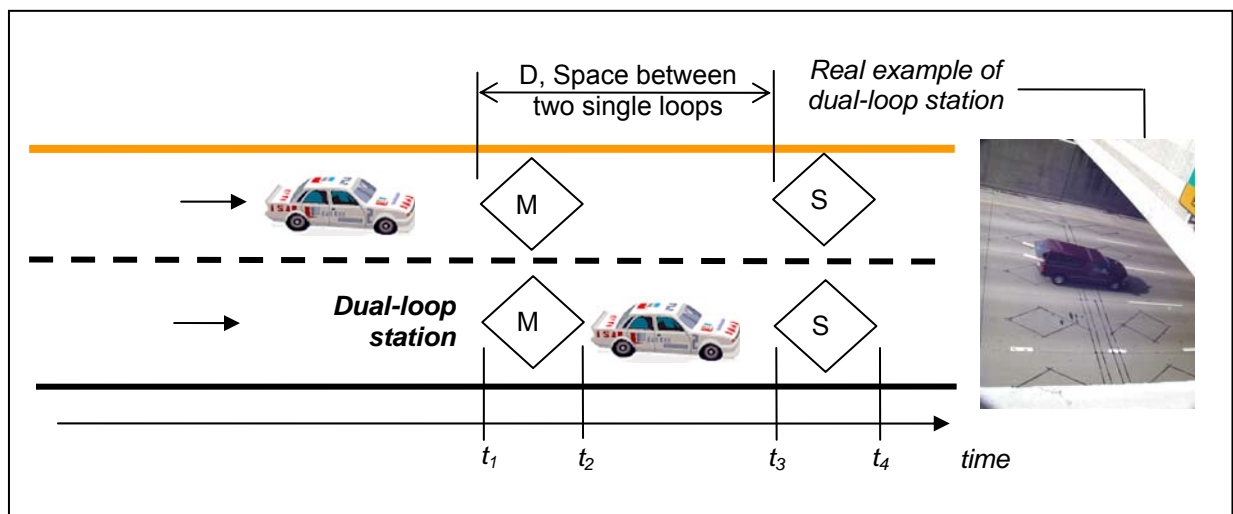

Figure 1. Sketch of Dual-loop Detector Station

The information resulting from detector data needs to be sufficiently accurate since any errors will propagate to decision-making and control actions. However, the existing loop models for measuring speed and vehicle classification is theoretically fitting to the case as vehicles run over the detection area at a constant speed. Those models have been evaluated only against light traffic and big errors have been reported within congested traffic (Nihan et al. 2006, Coifman 1999 and 2004, and Coifman and Kim 2008). Especially, when the stop-and-go traffic occurs directly over the dual-loop detector, it is unclear how the accuracy of the loop data will be affected by the traffic flow characteristics (Ohio Department of Transportation 2007).

The existing dual-loop length-based vehicle classification model is expressed as follows (Nihan et al. 2006).

$$speed = \frac{D}{t} \quad (1)$$

$$vehicel_length = speed \times \frac{OnT_1 + OnT_2}{2} - loop_length \quad (2)$$

Where, D = distance between two single loops in the dual-loop station (ft);

$$t = t_3 - t_1;$$

$$OnT_1 = t_2 - t_1; \text{ and}$$

$$OnT_2 = t_4 - t_3.$$

As illustrated by Figure 1, t_1 , t_2 , t_3 , and t_4 are timestamps when a vehicle enters or leaves the upstream loop (M loop) or downstream loop (S loop).

From the standpoint of traffic monitoring over a roadway network, the detection system does not cover the entire network, and often blank areas in the data in a corridor are fulfilled with interpolated data. Therefore, traffic counts over a corridor or over a network always contain certain degrees of errors (faults in the vehicle counts, missing data, outliers) (Viti et al. 2008, Kwon et al. 2007, and Fujito et al. 2006). It is still not clear what solutions to the sensor location problem can be applied to set up optimum locations of detection sensors for accurately measuring network traffic (Liu and Danczyk 2008; Mirchandani and He 2008; Fei and Mahmassani 2008; and Ban et al., 2008).

1.2 Identified Problems

Through literature review the problems in existence of dual-loop models for length-based vehicle classification and loop location are identified as follows:

- 1) The existing dual-loop length-based vehicle classification models produce large errors under non-free traffic conditions.
- 2) Errors mentioned in 1) may be contributed by the complex characteristics of traffic flows under congestion; but quantification of such contributing factors remains unclear.
- 3) The characteristics of different traffic states have not been appropriately considered in the existing dual-loop length-based vehicle classification models.
- 4) The optimal layout and location of dual-loop detectors remains a challenge and no reliable solution has been reported.

1.3 Goal and Objectives

The goal of this research project is to investigate the impact of the traffic flow on the dual-loop vehicle classification models against various traffic conditions and then develop new dual-loop

length-based vehicle classification models for congested conditions (i.e., synchronized and stop-and-go). In addition, detector standards that have been adopted in 17 states in the US and travel time estimate by dual-loop data will be summarized for better understanding of the current loops applications. To fulfill this goal, the following objectives are designated for the project:

- 1) To evaluate the existing dual-loop length-based vehicle classification model under non-free flow traffic condition so as to identify the impact of the traffic characteristics on the accuracy of estimating vehicle length and classification;
- 2) To develop new dual-loop length-based vehicle classification models under congested traffic; and
- 3) To collect loop detector standards of layout and installation in selected states in the US.

CHAPTER 2: LITERATURE REVIEW

2.1 Dual-loop Data Problems

The inaccurate dual-loop data may be caused by many reasons, and Zhang (2003) found analyzed the reason for incorrect sensitivity levels of a dual-loop detector. Nihan (2006) and Cheevarunothai (2006) believed that sensitivity problems were caused by factors of maker-specific standards and road materials, and it is very difficult to keep detectors' sensitivity at an appropriate level. Cheevarunothai (2006) proposed an algorithm to remove the sensitivity discrepancy between two single loops of a dual-loop station so as to adjust the sensitivities to the appropriate level. The algorithms which screen the collected data have been developed under light traffic; however, the influencing factors due to characteristics of congested traffic have not been firmly addressed (Coifman 1999 and Nihan 1997). There is a method for “eliminating error” data in current practice. When the occupancy difference between the first and second single loop detectors within a dual-loop station is found beyond 10 percent, or when the second single loop detector does not detect a vehicle in a reasonable amount of time, this sample will be discarded as an “error” (Nihan et al. 2002). However, during congested traffic, especially stop-and-go traffic, the occupancy difference of the first and second loops is often larger than 10 percent. Such an “eliminating method” would flag many real vehicle samples as errors and then lots of valuable samples may be misplaced into the discard. As a consequence, traffic flow would be greatly undercounted under heavy traffic, and the estimate of vehicle classification would be accordingly inaccurate.

2.2 Length-based Vehicle Classification Using Dual-loop Data

The length-based vehicle classification is based on loop data from two types of loop detectors: single loops and dual-loops. In some previous studies, single loop data were used to estimate vehicle speed and vehicle length (Coifman 2008, Kwon 2003, and Zhang 2008). Coifman (2008) proposed a method to use median speed, instead of mean speed, and *on-time* variable to estimate vehicle length. That method improves the accuracy of vehicle length estimation to some extent. Kwon (2003) proposed an algorithm to estimate traffic volume and the mean effective vehicle length. This algorithm works for multi-lane freeway where there is a truck-free lane, assuming that vehicle speeds over different lanes tend to have very small speeds variances

Using dual-loop data, vehicle speed and length can be estimated more accurately than single loops (Nihan 2006 and Viti 2008). The Ohio Department of Transportation (ODOT) length-based classification scheme for dual-loop detectors is capable of classifying vehicles into three bins (or called 3-bin scheme): vehicle length ≤ 28 ft (Bin 1), vehicle length ≤ 46 ft (Bin 2), and vehicle length > 46 ft (Bin 3) (Coifman 2004). The Washington State Department of Transportation (WSDOT) length-based classification scheme for dual-loop detectors can classify vehicles into four bins (or 4-bin scheme): vehicle length ≤ 26 ft (Bin 1), vehicle length ≤ 39 ft

(Bin 2), vehicle length ≤ 65 ft (Bin 3), and vehicle length > 65 ft (Bin 4) (Nihan et al. 2002 and 2006). Nihan et al. found that during off-peak hours and peak hours, “dual-loop detectors often mistakenly assign Bin 3 vehicles to Bin 4, but reverse assignments (Bin 4 vehicles to Bin 3) do not occur”, and “dual-loop detectors have difficulties distinguishing Bin 2 vehicles from Bin 3 vehicles. They sometimes assign Bin 2 vehicles to Bin 3”. For off-peak hour traffic, observed misclassification errors for truck ranges from 30 to 41 percent.

The event loop data is referred to a kind of high-resolution data that includes individual vehicle information, such as the timestamp of vehicle arriving or leaving the loop. Event dual-loop data are usually applied in traffic analysis in order to obtain accurate travel features of individual vehicles traveling over the loop (Chen et al. 1987, Turner et al. 2000, Coifman 2004a, Nihan et al. 2002 and 2006, and Chevarunothai et al. 2005). Based on the event dual-loop data, the traffic parameters, such as vehicle length, traffic count, speed, occupancy, density, and time headway can be obtained. Meanwhile, it has been proved that vehicle trajectory data from video is a reliable ground-truth data source for length-based vehicle classification (Nihan et al. 2002 and 2006, Coifman et al. 2004b). It has been proven that the event vehicle trajectory data from video is a reliable ground-truth event data for length-based vehicle classification (Coifman et al 2004a, 2004b, and Nihan et al. 2006). The software VEVID (Vehicle Video-Capture Data Collector) was developed to extract accurate trajectory data (Wei et al. 2005), and the accuracy of its outputs has been proven ground truth (Wei 2008). Therefore, the video event vehicle trajectory data can be extracted by using the software VEVID. Such a trajectory data set is also termed as VEVID-based data in this report.

2.3 Traffic Flow Characteristics

Edie (1961) proposed his linear models for two states of traffic flow: one is opted to represent the relationship between density and the logarithm of velocity above the “optimum velocity” within uncongested traffic flow; and the other represents the relationship between velocity and the logarithm of spacing (the inverse of density) under the congestion condition. In other studies discontinuities have been found frequently happened in flow-concentration data at around maximum flow, and some researchers tried to use multiple curves to model the part of the “discontinuities.” For instance, Koshi (1983) proposed a reverse lambda shape to describe the flow-density relationship. May (1990) employed “two-regime” models to describe the relationship of flow and concentration. It was found that at capacity, the models did not fit the data very well and at different locations and different times, different parameters should be adopted in the models. Hall (1986) proposed an inverted ‘V’ shape to represent the flow-occupancy relationship, and this model had been supported by many studies. Polus et al. (2002) proposed three regimes of traffic flow: free flow, dense flow, and unstable flow and they defined traffic breakdown as the change from dense flow to unstable flow.

The stop-and-go traffic is considered as a case of extremely unstable traffic. Kerner (1998) summarized that there is a density range where homogeneous states of traffic flow either due to

instability of the flow or due to some other kind of phase transitions that *cannot* exist, and the stop-and-go phenomenon therefore has to occur. Using data set provided by 12 counting loops all located at the German highway A1 near Cologne, Neubert (1999) revealed a qualitative difference between the free-flow state and the congested states (i.e., synchronized traffic and stop-and-go traffic) by calculating the time-headway distribution and the headway dependence of the velocity. Meanwhile, they used the autocorrelation and cross-correlation for the different time series to identify three qualitatively different microscopic states. It is found that the free-flow state is characterized by a strong coupling of the flow and density, and beyond that by a slow decay of the related autocorrelation functions. Helbing (1999) used Phase diagram to describe the traffic states and the congested traffic is categorized into four states: homogeneous congested traffic, oscillatory congested traffic, triggered stop-and-go traffic, and moving localized cluster. Kerner et al. (1994 and 1998) defined traffic flows in three categories: free flow, synchronized flow, and stop-and-go flow, as shown by Figure 2.

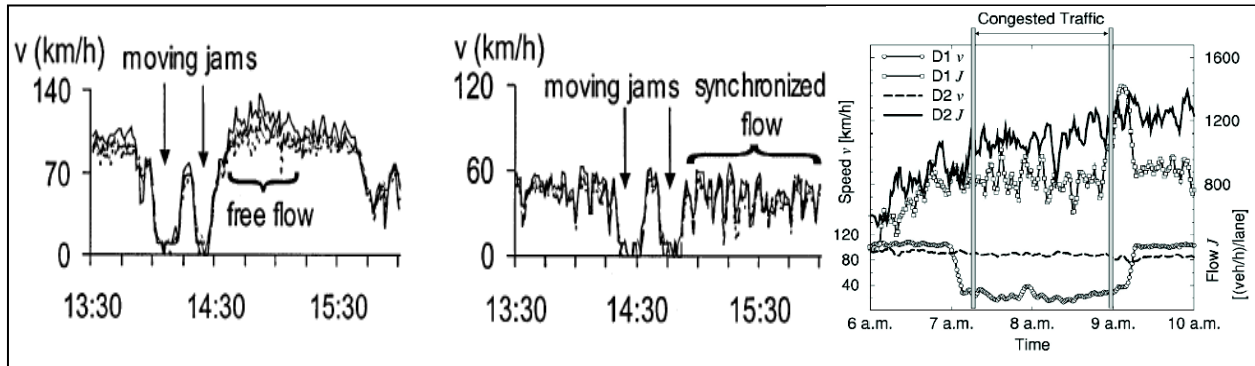

Figure 2. Demonstrations of Three Traffic Patterns (Kerner et al.)

The free flow has high travel speed and low traffic volume and density. The synchronized flow is viewed as a kind of congested traffic, which has relative low speed and high volume and density. The speed of the synchronized traffic stream fluctuates frequently but its average speed remains at a relatively stable level. The stop-and-go traffic flow features very congestion condition, as speed and volume are very low while the density is very large. The vehicle speed not only fluctuates frequently, but also the vehicle stops from time to time. Thus, within the synchronized and stop-and-go traffic flows, it is highly possible for the vehicles to run over the upstream and downstream loops at different speeds. Thus, accelerations or decelerations may exist as running over the dual-loop station. Within the stop-and-go traffic flow some vehicles may experience multiple stops within the detection area.

2.4 Thresholds for Distinguishing Traffic States

Athol (1965) suggested that volume and occupancy could be used together to identify the onset of congestion: “the transitions between uncongested and congested operations at volumes lower

than capacity.” Zhang et al. (2009) used four features to characterize an oscillatory traffic pattern: the occurrence of oscillation, the offset of the oscillation patterns different lanes, the oscillation period, and the oscillation amplitude in flow levels. They set the jam density of 240 veh/mile/ln, and the flow speed v and wave speed w of each link 50 mile/hour and 10 mile/hour, respectively. In their study, the oscillations at a lane-drop site are the result of traffic interactions initiated at the two lane-changing locations traveling between these two locations in the forms of different kinds of kinematic waves (e.g., shockwaves, acceleration waves, etc.).

Lorenz et al. (2001) defined a traffic breakdown as the traffic condition in which the average speed of all lanes on a highway section decreased to below 90 km/h for at least a 15-minute period, and then Elefteriadou et al. (2003) changed the speed threshold as of below 80 km/h for at least a 15-minute. However, other studies indicated that speed only is not sufficient to ensure the identification of traffic congestion. Congestion may not be detected by using the speed-based algorithm only, and “perhaps the optimal speed thresholds are different above a certain occupancy threshold” (Wieczorek et al. 2010). Kerner (2004) used a FOTO (Forecasting of Traffic Objects) model to recognition and tracking congested traffic. They classified the flow rates by fuzzy logic into the values “low” and “high”, and speeds are classified into the values “low”, “medium”, and “high”, respectively. Then the classification of the traffic phases is based on a comparison of measured flow rates and vehicle speeds in different traffic states and a fuzzy inference system is used to perform the classification.

Habib-Mattar et al. (2009) defined the beginning of the unstable flow using speed and density. In their definition, the unstable flow occurs as both the following conditions concur: (1) the speed decreases to below 60 km/h (37 mph) and this situation lasts for at least a 5 minutes; and (2) the density increases firstly and becomes great than 40 veh/km/lane. They developed a model, which is composed of an exponential model, a logistic model, and a weighting function, which focuses on the changes of density, especially before the breakdown:

$$H = DE(t) * (1 - W(t)) + DL(t) * W(t) \quad (3)$$

$$DE(t) = \alpha_E e^{\beta_E * t} \quad (4)$$

$$DL(t) = \frac{L_{max}}{1 + e^{(\alpha_L + \beta_L * t)}} \quad (5)$$

$$W(t) = \frac{1}{1 + e^{(\alpha_w + \beta_w * t)}} \quad (6)$$

Where, $DE(t)$ = density in time t in the exponential model (veh/km);

t = time from midnight (sec);

α_E, β_E = parameters of the exponential model;

$DL(t)$ = density at time t in the logistic model (veh/km);

L_{max} = average value of density in the unstable flow (veh/km);

α_L, β_L = parameters of the logic model;

$W(t)$ = weighting function; and
 α_W, β_W = parameters of the weighting function.

Habib-Mattar et al. (2009) also recommended speed thresholds for identifying the traffic breakdown for different types of freeway segments, and the thresholds are dependant upon on local geometric and traffic features of the facility. Chow et al. (2010) used speed drop to describe the traffic transition. They proposed that if the speed drop is greater than 5mph within 5 minutes, the system is considered to be unstable and the current traffic state is going to transit to another state.

Based on literature review, the thresholds for distinguishing the traffic states are summarized in Table 1.

Table 1. Summary of Thresholds of Traffic States Used in Previous Studies

Researchers & Year	Traffic States Indicators				
	Speed	Volume	Density or Occupancy	Others	Notes
Athol (1965)		Yes	Yes		To identify congested and uncongested traffic
Zhang et al. (2009)	50 mph		Jam density = 240 veh/mile/lane	Wave speed=10mph	To identify oscillatory traffic pattern
Habib-Mattar et al. (2009)	< 37 mph for at least a 5-minute period		64 veh/mile/lane		To identify the unstable flow
Elefteriadou et al. (2003)	< 50 mph for at least a 15-minute period				To identify traffic breakdown
Chow et al. (2010)	Speed drop >5mph during 5-minute period				Traffic transition may happen
Kerner (2004)	Yes	Yes			A fuzzy logic model is used to identify traffic transition

CHAPTER 3: VEHICLE CLASSIFICATION UNDER DIFFERENT TRAFFIC STATES

In this chapter, the dual loop data and the current vehicle classification model are evaluated against concurred ground-truth video event vehicle trajectory data. Figure 3 illustrates the framework guided for this evaluation.

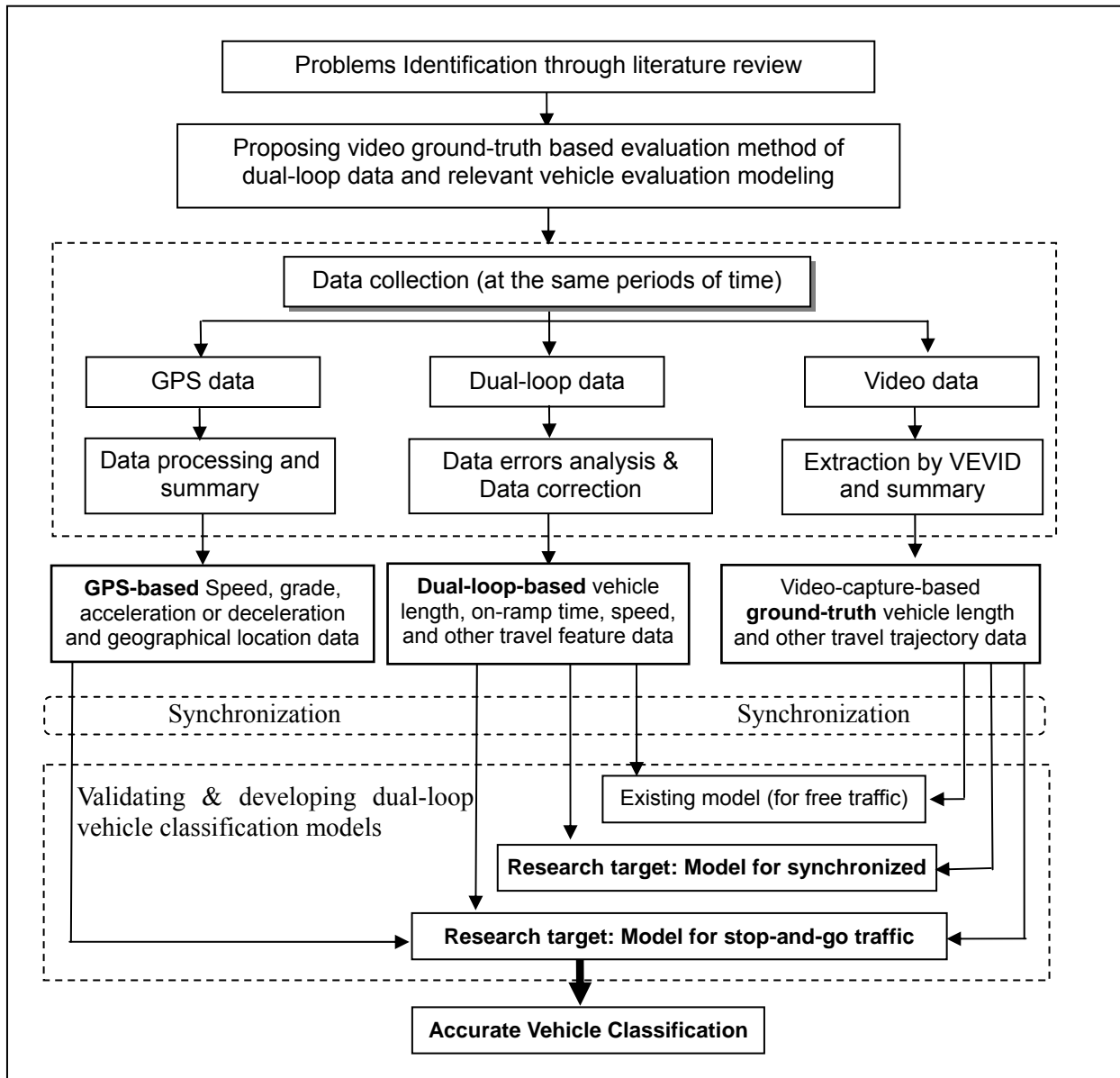

Figure 3. Framework of Evaluating Dual-loop Data Based Vehicle Classification Models

The first stage is to collect data. The traffic video data over the selected dual-loop detector stations will be collected using digital camcorders, and the concurrent dual-loop data

will be collected at the traffic management center. Those stations are located in reoccurring congestion areas and also in good working condition. Meanwhile, the GPS (Global Positioning System) data is collected with GPS travel data loggers.

The traffic video data are processed in VEVID to extract vehicle speed, vehicle length, timestamps of its entering and leaving each single loop. The concurrent dual-loop data is processed by a newly developed algorithm to remove data errors caused by vehicle lane-changing and communication problems. With availability of both event dual-loop and VEVID-based vehicle event data, the errors of dual-loop data could be identified and corrected. The errors and possible causes could be effectively investigated against three traffic conditions, namely, free, synchronized, and stop-and-go states. The evaluation result inspires the development of new models for congested traffic flows. The GPS data is of the supplementary aligned with video and dual-loop data to reveal the pattern characteristics of different traffic states, which are helpful to scenario development for of new length-based vehicle classification models under congested traffic.

3.1 Study Sites

At two selected study sites, there are dual-loop detector stations with good working conditions and the traffic flows over the loops can be videotaped. The following factors are considered in selecting the study sites:

- Recurring traffic congestion exists in the study site where a dual-loop station is already installed and put into practice;
- The dual-loop station is in good working condition and its event loop data can be obtained; and
- The loops can be clearly visible at a nearby elevated place where video cameras can be placed to film the traffic over the dual-loop station.

Two loop stations, numbered as V1002 and V1003, in Columbus, Ohio were eventually selected as the study sites. As shown by Figure 4, the V1002 station is located in I-70/71 at West Mound Street within downtown Columbus, which has 6 dual-loop detectors in both directions. The Franklin County Juvenile Parking Garage is near this station, and a video camera is placed on the top floor of it. Figure 5 shows the loop station V1003, located in I-70/71 at South 4th Street, which is about 1 mile away from the V1002. At this station, there are 3 dual-loop detectors in the westbound and no detectors in the eastbound. There is an elementary school near this station and a video camera is placed at the parking lot of the school to shoot the traffic on the freeway. ODOT Traffic Management Center (TMC) is running those stations and provides the loop data.

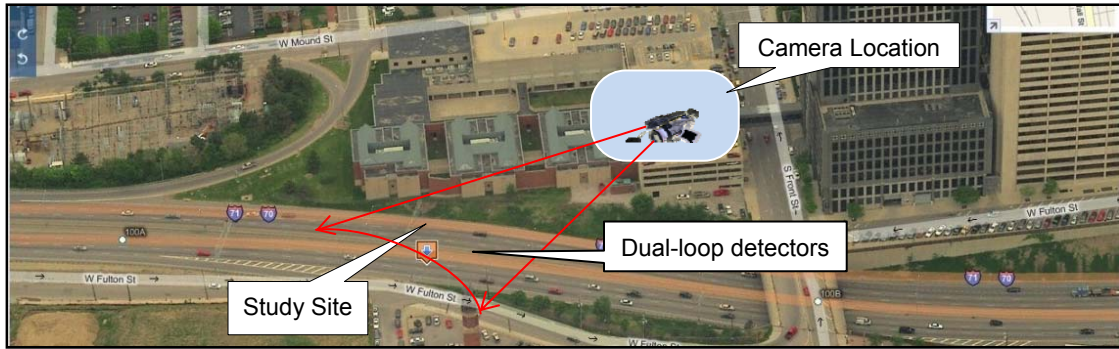

Figure 4. Loop Station V1002 on I-70/71 in Downtown Columbus, OH

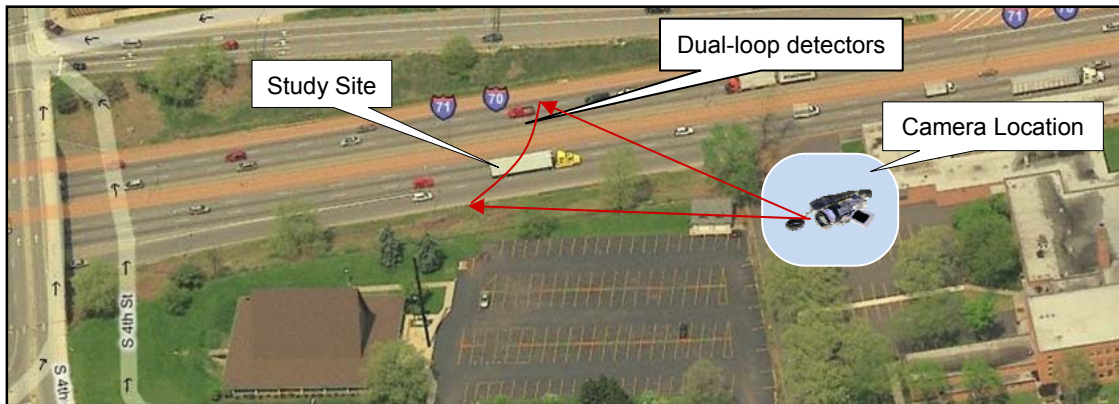

Figure 5. Loop Station V1003 on I-70/71 in Downtown Columbus, OH

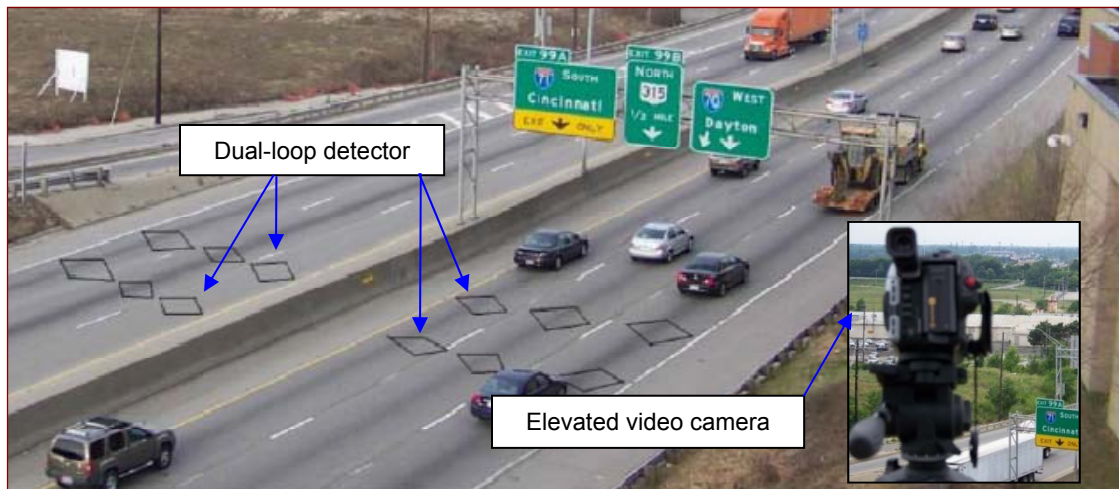

Figure 6. Videotaping at the Selected Dual-loop Station

3.2 Data Collection

3.2.1 Video Data Collection

An elevated place near the study site is carefully selected for installing the video camera so as to

film the traffic passing over the loops. **Error! Reference source not found.** Figure 7 illustrates the layout of the camera for video data collection.

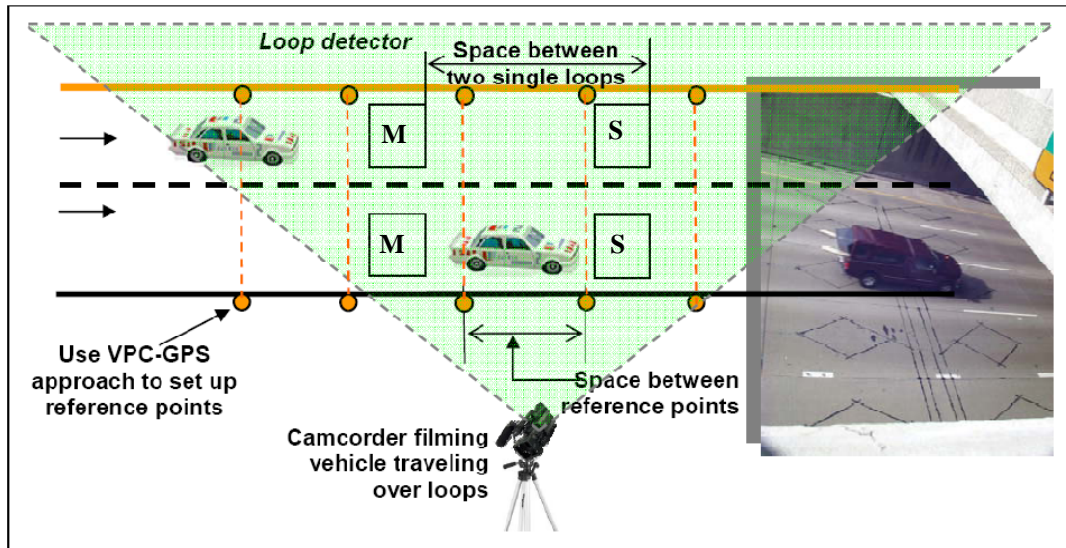

Figure 7. Illustration of Video Data Collection at a Selected Study Site

The periods of videotaping include morning and evening peak hours and off-peak hours. For the sake of safety, a new approach named is developed to set up reference points in VEVID to remove the concerns about staffs working in the field. Since techniques or technologies applied in this approach include Video-capture, Perspective drawing, vehicle Cruise control, and GPS-based Probe, it is named as VPC-GPS approach. This approach will be discussed in details in Section 3.3.2 Setting Up Field Reference Points for VEVID. Three-day traffic videotaping was conducted from July 14, 2009 to July 16, 2009. A total of 26 hour traffic video data were collected, including light traffic and congestion traffic flows (i.e., synchronized traffic and stop-and-go traffic).

3.2.2 Event Dual-loop Data Collection

The concurrent event loop data obtained from the ODOT TMC is the raw data from dual-loop detectors, which record the timestamps of each vehicle as it enters and leaves each loop. The scanning frequency of the dual-loop is 60 Hz. In other words, occupied status of a loop is automatically updated 60 times per second. The exemplary sample of the event dual-loop data is illustrated in Table 2. The timestamp with status value of “1” indicates the time when a vehicle enters the loop, and the timestamp with the status value of “0” is the time when the vehicle leaves the loop. The timestamp indicates the moment at which a vehicle is detected by a single loop, and it is calculated as follows: 1) taking the midnight (00:00:00) as the start point: 0; 2) using 1/60 second as the time unit. For instance, if a vehicle is detected at 16:15:43, the timestamp = $16 \times 60 \times 60 + 15 \times 60 + 43 \times 60 = 3512580$. On the other hand, if a timestamp is 3522267, then, $hh = \text{INT}(3522267 / (60 \times 60 \times 60)) = 16$; $mm = \text{INT}((3522267 - hh \times 60 \times 60 \times 60) / 3600)$

= 18; ss1 = INT((3522267 - hh*60*60*60 - mm*60*60)/60) = 24; ss2 = 3522267- hh*60*60*60 - mm*60*60 - ss1*60 = 27, or, ss = ss1 + ss2/60 = 24+27/60 = **24.45**. Therefore, the corresponding event is supposed to be happened at 16:18:24.45.

Table 2. Exemplary Sample of the Event Dual-loop Data

M loop (Upstream)		S loop (Downstream)	
Status	Timestamp	Status	Timestamp
1	3522267	1	3523667
0	3524341	0	3524489
1	3524504	1	3524652
0	3524675	0	3524795
1	3524817	1	3524919
0	3525598	0	3525914

3.2.3 GPS Data Collection

GPS data can be used to trace the vehicles' speed and speed change at a time interval during a travel journey. Such a data set is very helpful to revealing traffic features of stop-and go traffic flows. A GPS travel data logger is equipped in a testing car, and this car runs along a freeway segment of I-70/71 which covers the two selected study sites. The GPS travel data logger enables accurate recording of travel speed at one second interval. Using the software TravelRecorderV4, which comes with the GPS data logger, the speed of the probe vehicle at every second can be shown along the study route. **Error! Reference source not found.** The GPS data can be exported into an Excel file. Table 3 shows a sample of the data which includes the probe vehicle's locations, altitudes, and speeds at different time intervals.

Table 3. Exemplary Sample of GPS Data Imported into Excel File

Index	Date	Time	Latitude	N/S	Longitude	E/W	Altitude	Speed (km/h)
1	6/18/2009	9:11:20	39.153718	N	84.538517	W	121.0784	34.31250
2	6/18/2009	9:11:21	39.153794	N	84.538484	W	121.3541	30.37852
3	6/18/2009	9:11:22	39.153867	N	84.538450	W	121.4104	29.87616
4	6/18/2009	9:11:23	39.153934	N	84.538418	W	121.3969	30.09646
5	6/18/2009	9:11:24	39.153995	N	84.538403	W	126.0297	29.97442
6	6/18/2009	9:11:25	39.154064	N	84.538364	W	126.6021	30.75053
7	6/18/2009	9:11:26	39.154137	N	84.538320	W	126.5208	31.86823
8	6/18/2009	9:11:27	39.154210	N	84.538276	W	127.1036	31.32330
9	6/18/2009	9:11:28	39.154279	N	84.538230	W	127.7191	31.09699

Figure 8 illustrates the procedure of the GPS data logger and a testing sample data diagram along a sample route. Statistical analysis of the obtained GPS data results in the estimates of the following parameters: (1) average acceleration or deceleration rate; and (2) average minimum speed. These parameters are used to quantify some variables involved in the developed vehicle classification models under the stop-and-go traffic condition.

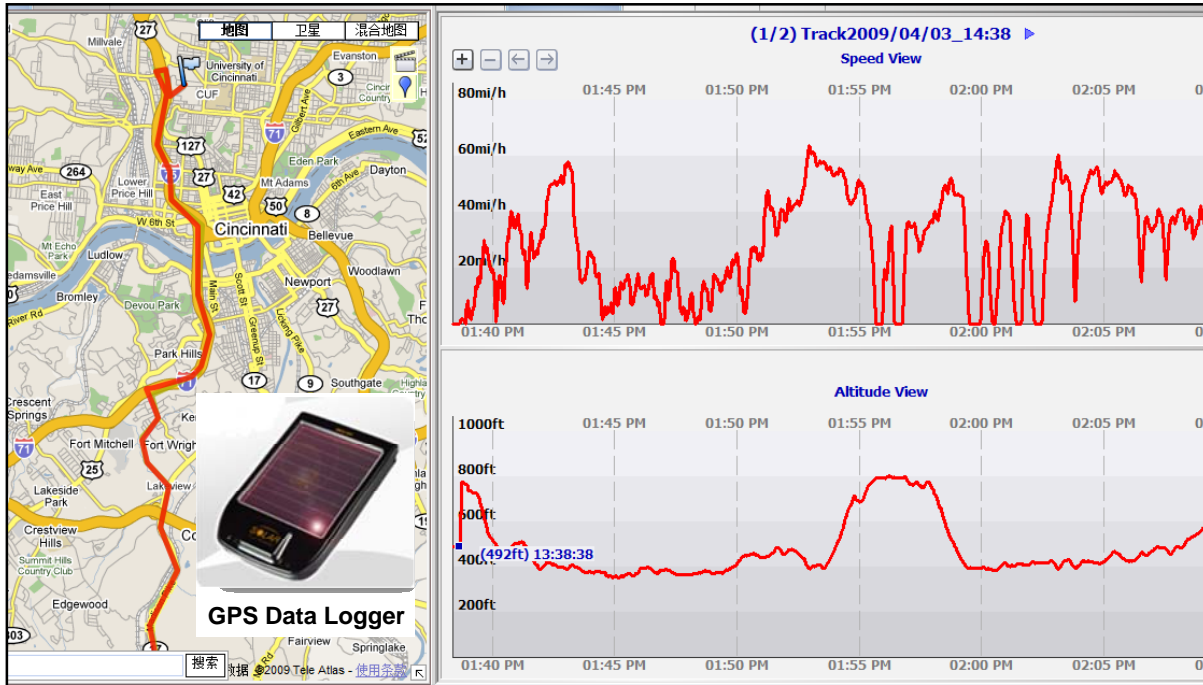

Figure 8. The GPS Data Logger and the Interface of Its Software

According to the GPS data logger’s manual, the accuracy of location positioning is within 3m and the error of velocity measuring is less than 0.33ft/s. In this study, the vehicle’s acceleration is calculated based on the change of two consecutive speeds during one second interval. Thus, the error of acceleration is less than 0.66ft/s^2 . For the purpose of quantifying traffic characteristics, such accuracy is good enough for this study.

3.3 Video Trajectory Data Extraction

3.3.1 Introduction of VEVID

In this study, the video-capture-based approach is used to extract the ground-truth trajectory data from videos by using the software VEVID. VEVID was originally developed by the PI of this project and then upgraded by him and his PhD student, Mr. Zhixia Li at the Advanced Research in Transportation Engineering and System (ART-Engines) Laboratory at The University of Cincinnati [13, 14]. The input video file of VEVID is an AVI file, and the video’s frame rate set up in the AVI file can be automatically identified by VEVID. So the time interval of two consecutive frames is determined and the distance a vehicle travels between these two

consecutive frames can be calculated based on the vehicle's position change from one frame to the immediately next frame. In this way, acceleration, relative spacing and/or headway of the vehicles in a traffic platoon, as well as other relevant travel features, can be calculated and stored in the vehicle trajectory data via VEVID.

3.3.2 Setting Up Field Reference Points for VEVID

In VEVID, the real distance between two points is calculated by an embedded algorithm once those corresponding points are clicked on the monitor screen. Running this algorithm requires setting up the reference points system in advance within VEVID by using the video that films the process of marking the references points in field. We used to set up the reference points in field by manually marking the points on the surface of the sidewalk along both sides of the roadway (Figure 9). This method works very well in local streets; however, it will obviously bring a safety concern if this method is applied in freeways.

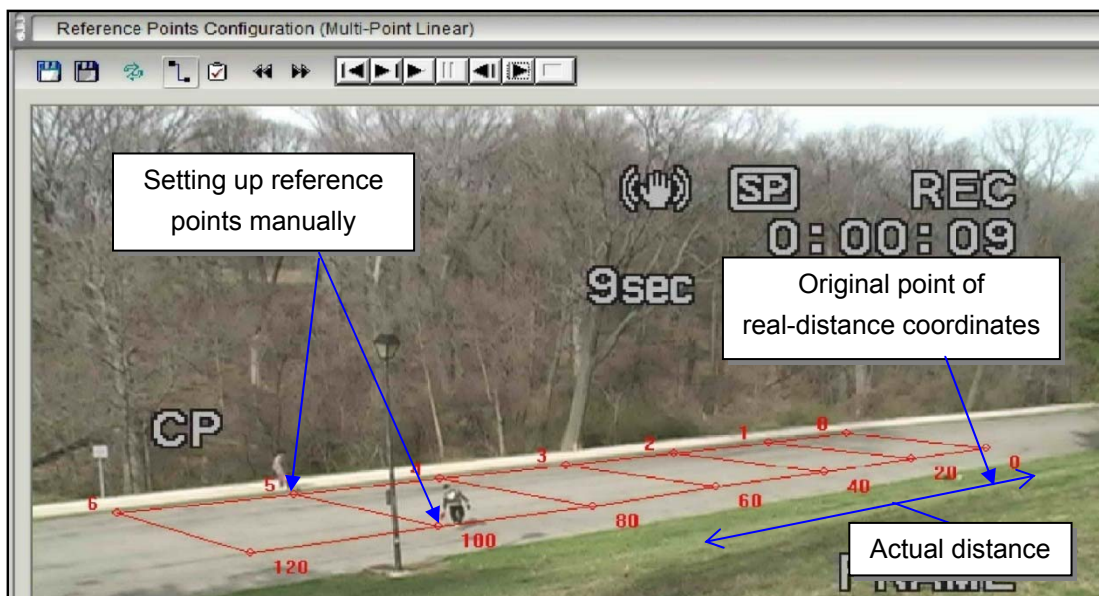

Figure 9. Setting up Reference Points Manually (Distance between points: 20ft)

Therefore, a new approach is needed to create the reference points with no need for staffs to physically stay in field. In this new approach, the GPS-equipped probe vehicle with the aid of cruise control function is used to measure the speed and provide vehicle positioning video frames. Figure 10 illustrates the procedure of applying the VPC-GPS approach in determining the reference points in field.

Video-capture and linear perspective drawing techniques are used to determine the reference points from the video frames by VEVID software. The speed probed by the testing vehicle is used to determine the reference spacing intervals, and then a real-distance coordinate system is registered in VEVID. Since Video-capture and Perspective drawing techniques, Cruise control function, and GPS-based Probe technology constitute such a Systematic approach, this new approach is named as the VPC-GPS approach. When this approach is applied, the vehicle's

cruise control is used to fix the speed and the GPS Travel Data Logger is used to accurately measure the speed, S (ft/s). In VEVID, the video frame rate F (frames/s) can be selected, and the travel time between two consecutive frames is calculated by $t = 1/F$. Then, the travel distance between two consecutive frames D (ft) is determined by multiplying S and t . Figure 11 illustrates an interface showing the reference points set.

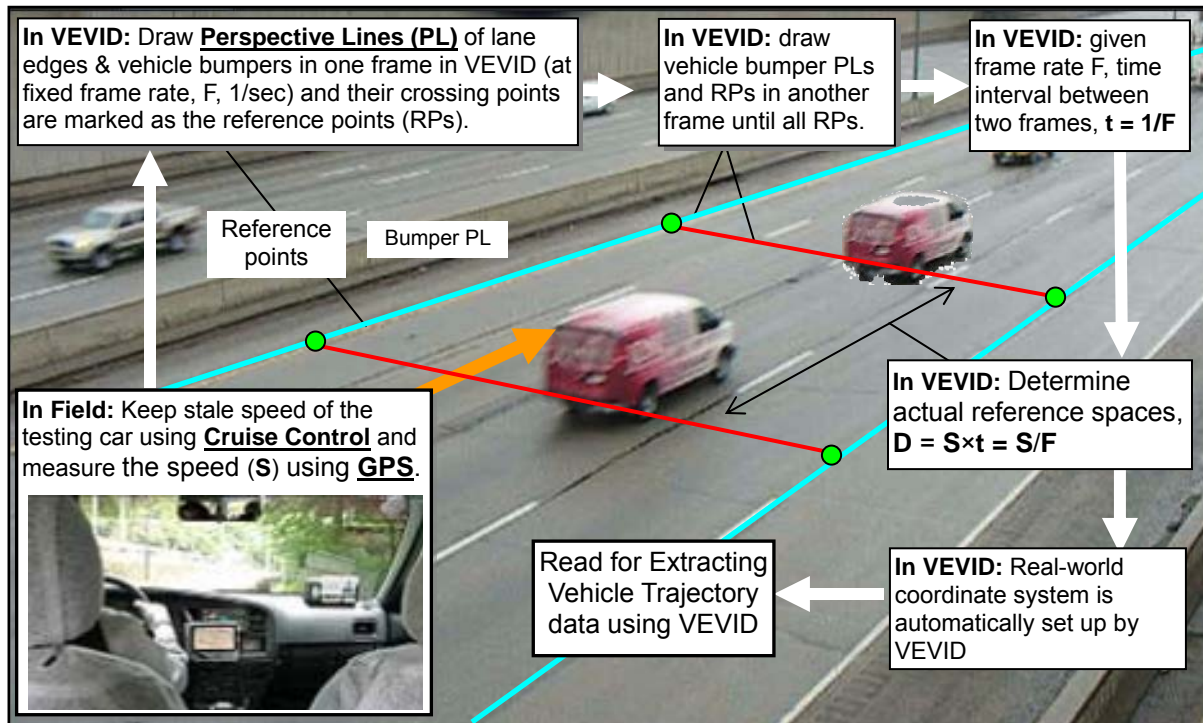

Figure 10. Procedure for Setting Reference Points using VPC-GPS Approach

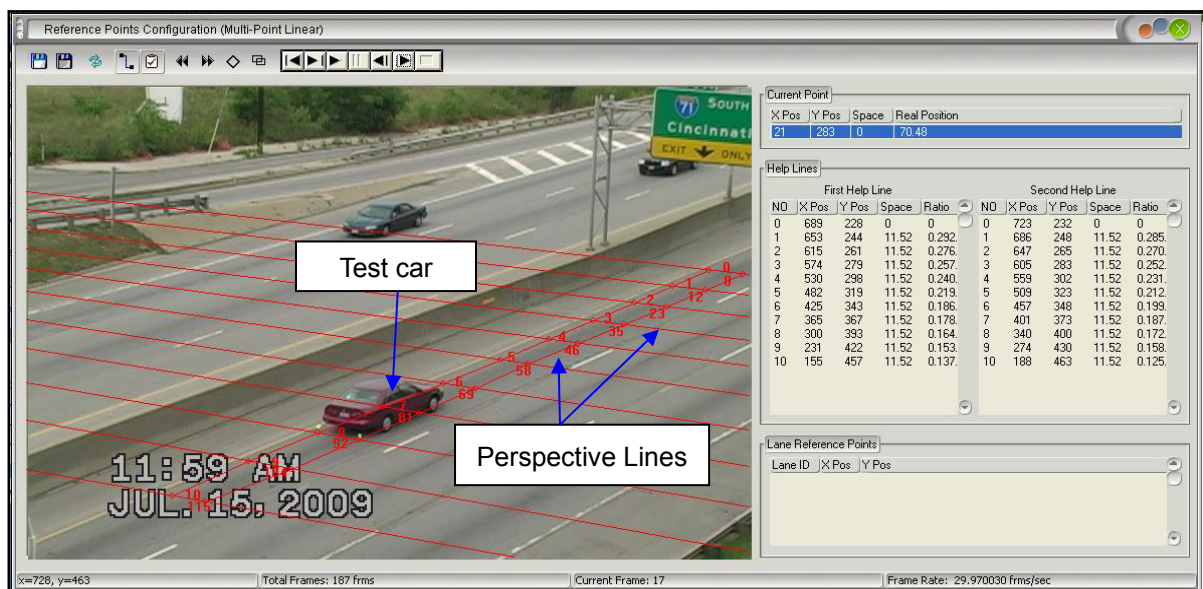

Figure 11. Reference Points Set in VEVID using VPC-GPS Approach

3.3.3 Vehicle Trajectory Data Extraction

After the reference points are set up and registered in VEVID, the vehicle trajectory data can be extracted by clicking the selected vehicles in VEVID. A distinguished point (e.g. rear tire) of a vehicle is identified firstly and then this point is clicked on each of the video frames that show the course of the vehicle's movement. The location difference of the clicked points on two consecutive frames is the distance the vehicle travels during the time between those frames. Since the time interval between two consecutive frames is fixed, the speed and other travel parameters of the studied vehicle can be calculated by a program in VEVID. In order to measure the length of vehicle, click the vehicle's rear bumper and front bumper on the same frame, respectively. So the difference between these two points is used to measure the real length of the vehicle. Table 4 shows exemplary extracted trajectory data.

Table 4. Sample Data Extracted from Video Using VEVID

Vehicle No.	Speed on M loop (mph)	Speed on S loop (mph)	On_time 1 (M loop) (sec)	On_time 2 (S loop) (sec)	Vehicle Length (ft)
1	18.24	17.74	0.6333	0.7000	8.7
2	18.06	15.36	1.1000	1.2667	18.1
3	16.14	13.96	1.1333	1.2667	16.1
4	14.83	12.69	1.1333	1.3333	13.7
5	13.85	12.32	1.2667	1.4667	15.8
6	11.36	9.92	1.5333	1.6333	17.1
7	10.26	9.54	1.6000	1.7667	14.8
8	12.92	8.37	2.0000	2.1667	17.0
9	8.99	8.62	2.2000	2.4333	19.4
10	9.75	8.74	1.8333	2.0000	13.6

Note: M loop: Upstream loop; S loop: Downstream loop.

3.4 Dual-loop Data Processing

3.4.1 Existing Problems in the Original Event Dual-loop Data

The original event dual-loop data is received from the ODOT TMC, which is directly downloaded from the loop station controllers without any aggregating and processing treatment. Some possible errors may exist in the raw data due to the impact of vehicle lane changes or other communication problems. These errors must be identified and eliminated before the data is used for evaluation. The vehicle lane-changing phenomenon results in missing data either of upstream loop (M loop in Figure 7) or of downstream loop (S loop in Figure 7). In a lane-changing maneuver, a vehicle may pass over the M loop and leave this lane to change to an adjacent lane without entering the S loop of the current lane, or a vehicle may come from another lane and directly run over the S loop of the current lane. The normal event dual-loop data is marked with a

timestamp of “1” status (occupied) followed by a timestamp of “0” status (not occupied) (see Table 2). Communication problem may cause fake timestamps on loops. When communication problems happen, there are some errors like a timestamp of “1” status followed by another timestamp of “1” status, or a timestamp of “0” status followed by another timestamp of “0” status. In these cases, the timestamps of the M loop and the S loop usually are not matching up. For instance, at the V1002 loop station, the total 24-hour counts of the M loop in eastbound lane 1 is 345632, while those of the corresponding S loop in this lane is 345421. Meanwhile, it is hard to determine which pairs of the data points represent the same vehicle running from the M loop and the S loop, respectively.

3.4.2 Algorithms of Original Event Dual-loop Data Processing

In order to eliminate the errors mentioned in the previous section, an algorithm is developed to pre-treat the original event dual-loop data. The whole procedure includes the following steps:

- Step 1: Dealing with communication-related error. A normal event dual-loop data is with a timestamp of “1” status followed by a timestamp of “0” status. If the first timestamp is not “1” status, a communication related error may occur to this data, and this record is then removed until the first timestamp of “1” status appears. If the next timestamp is not “0” status, this record will be removed until “0” status appears, and this “0” status should be followed by another “1” status. The step is repeated until all data points are checked and corrected.
- Step 2: Dealing with errors due to a vehicle coming from another lane without running over the M loop. T_u represents timestamps of the M loop and T_d is timestamps of the S loop (Table 5). $T_{u1}(i)$ and $T_{u2}(i)$ are the timestamps when the i^{th} vehicle enters the M loop and then leaves the M loop. Similarly, $T_{d1}(i)$ and $T_{d2}(i)$ are the timestamps when the i^{th} vehicle enters the S loop and then leaves the S loop. If $T_{d1}(i)$ is less than $T_{u1}(i)$, it means that $T_{d1}(i)$ happened before $T_{u1}(i)$. Since it is impossible for the vehicle to arrive at the S loop first, the vehicle that directly runs over the S loop must come from an adjacent lane. Thus, this $T_{d1}(i)$ does not have a corresponding $T_{u1}(i)$ aligned with it and will be removed from the data set.

Table 5. Timestamps of the M Loop and the S loop

M loop (Upstream)		S loop (Downstream)	
Status	Timestamp	Status	Timestamp
1	$T_{u1}(i)$	1	$T_{d1}(i)$
0	$T_{u2}(i)$	0	$T_{d2}(i)$
1	$T_{u1}(i+1)$	1	$T_{d1}(i+1)$
0	$T_{u2}(i+1)$	0	$T_{d2}(i+1)$
1	$T_{u1}(i+2)$	1	$T_{d1}(i+2)$
0	$T_{u2}(i+2)$	0	$T_{d2}(i+2)$
...

Step 3: Dealing with errors due to a vehicle leaving the concerned lane before entering the S loop. In Table 4, when $T_{u1}(i+1)$ is less than $T_{d1}(i+1)$ and at the same time $T_{u1}(i+1) - T_{d1}(i)$ is less than $T_{u1}(i) - T_{d1}(i)$, it means that $T_{d1}(i)$ happened much closer to $T_{u1}(i+1)$ than $T_{u1}(i)$. It indicates that $T_{u1}(i+1)$ and $T_{d1}(i)$ are more likely a data pair representing the same vehicle, and $T_{u1}(i)$ and $T_{u2}(i)$ should be the timestamps of a vehicle which enters the M loop and leaves the studied lane before it reaches the S loop. So the timestamp $T_{u1}(i)$ and $T_{u2}(i)$ will be removed from the data set.

To help better understand the above steps, in particular the Step 2 and Step 3, Figure 12 illustrates a flowchart which aims to identify and eliminate the errors due to lane-changing behaviors. This algorithm compiled in MatLab has been verified against ground truth data extracted from the video data.

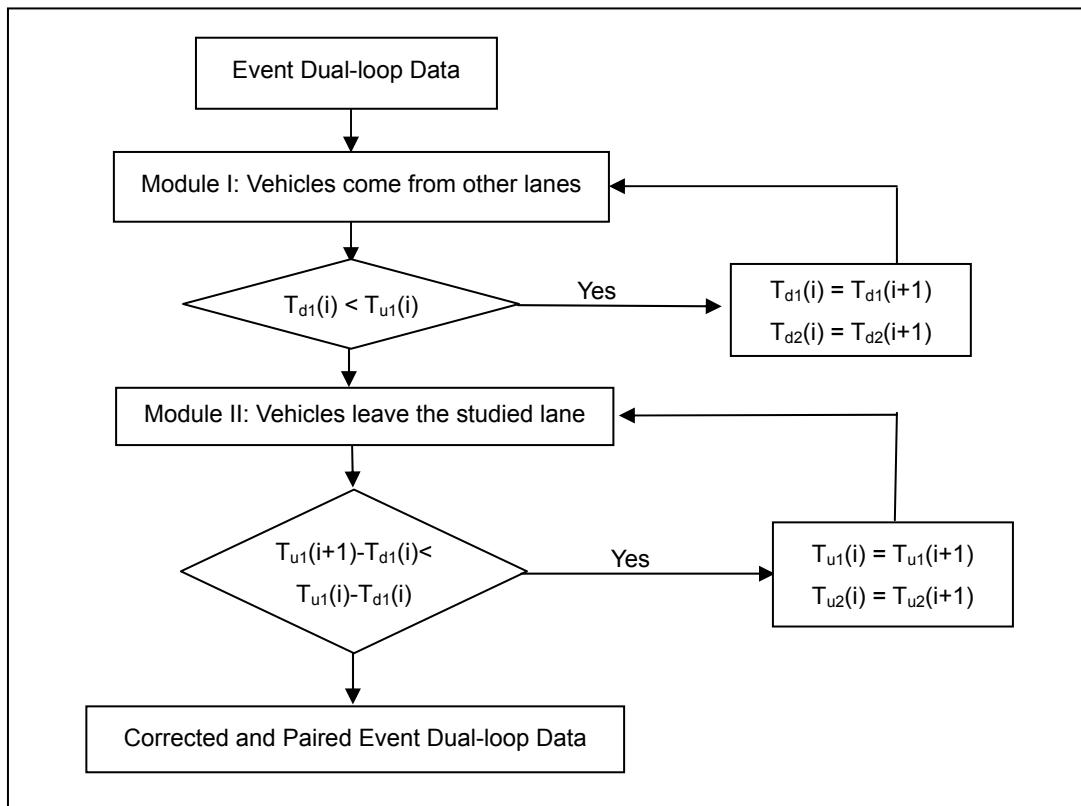

Figure 12. Algorithm of Removing Data Errors Caused by Vehicle Lane-changing

3.4.3 Loop Sensitivity Analysis

Cheeverunothai et al. (2006) found that one cause of dual-loop data error is the inappropriate sensitivity level. The sensitivity can be classified into two categories: sensitivity discrepancies between the M loop and the S loop, and unsuitable sensitivity levels of both the M and S loops. In their study, if the on-time differences are greater than ± 10 percent, a sensitivity problem is considered in existence. If such a sensitivity problem is detected through comparisons with the on-times of the ground-truth data, the virtual dimension of the loop detector is calculated. As

illustrated by Figure 13, this virtual dimension is different from the physical dimension of the loops, and the virtual dimension will be viewed as the as the size of the detector dimension in the following vehicle classification modeling.

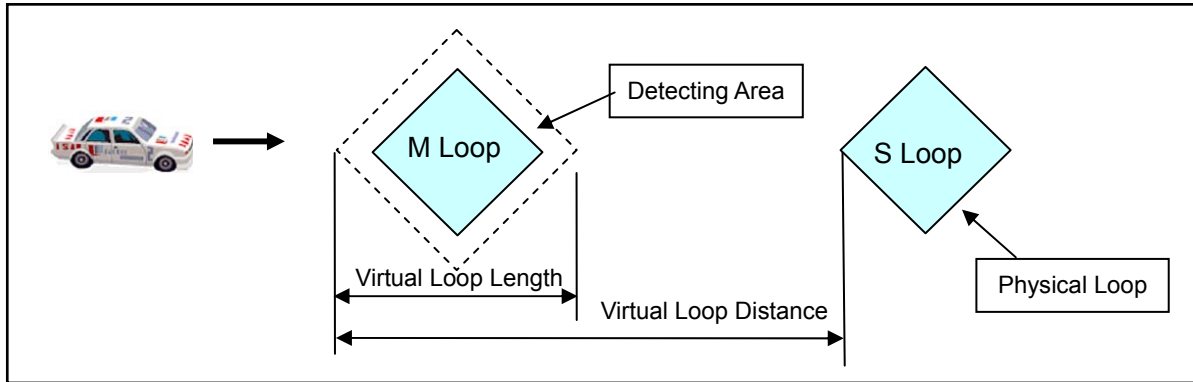

Figure 13. Sketch of Dual-loop Sensitivity Analysis

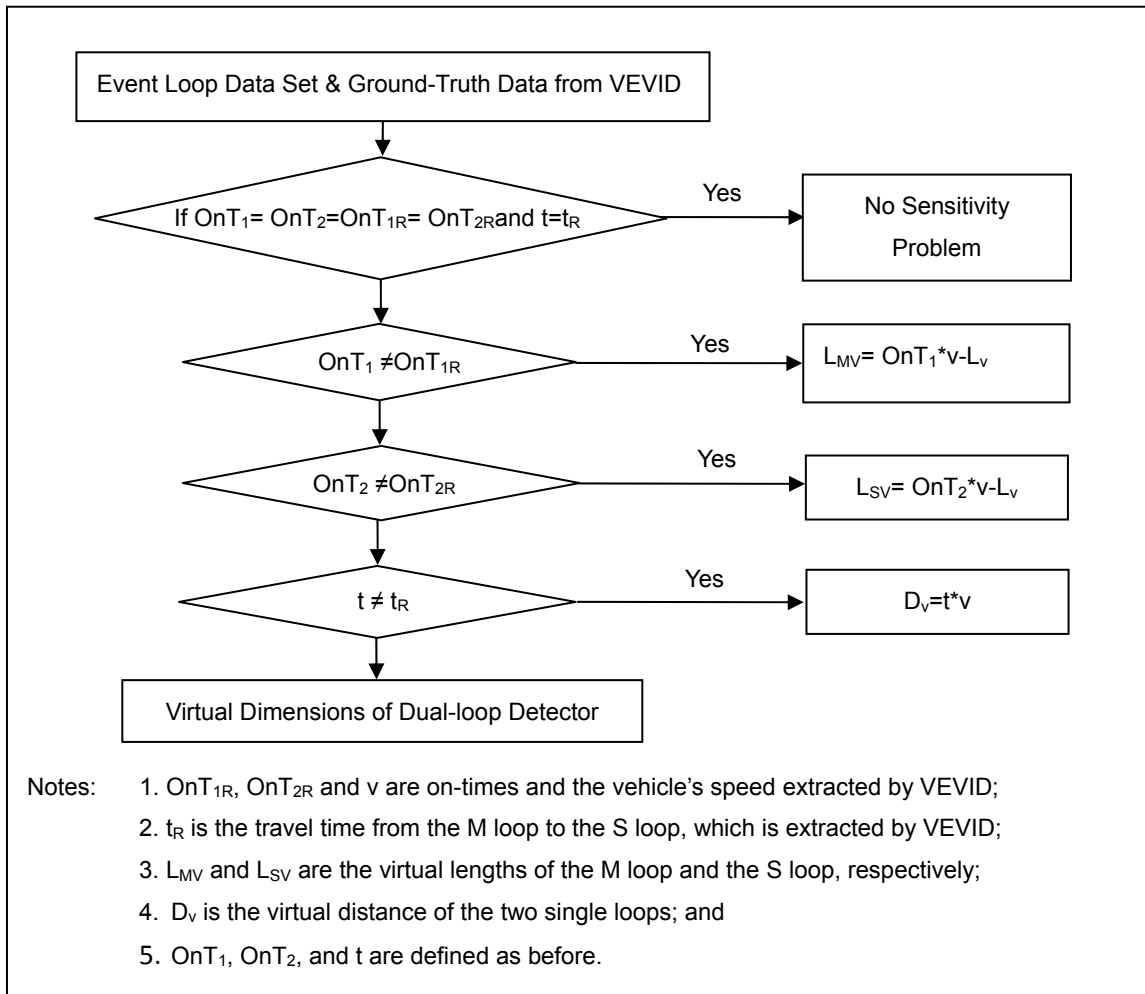

Figure 14. The Flowchart of Sensitivity Analysis

A set of data of small vehicles (vehicle length < 26 ft) under free traffic flow is applied for sensitivity analysis. Theoretically, the on-time of the M loop and that of the S loop are assumed the same under free flow, and it should be more true to smaller vehicles. The on-times (OnT_1 and OnT_2) and travel time from the M loop to the S loop (t) calculated based on the event loop data are compared with the corresponding ground-truth data extracted by VEVID. In this study, the criteria used by Cheevarunothai et al. (2006) are adopted to check a sensitivity problem. The flowchart as shown by **Error! Reference source not found.**Figure 14 demonstrates the algorithm for analyzing the dual-loop sensitivity.

3.5 Traffic States Identification Algorithm

Correct identification of varied traffic flow states is one vital factor influencing development and application of the length-based vehicle classification modeling at dual-loop stations. As mentioned in Chapter 2, only one variable is difficult to represent distinguished characteristics of different traffic flow states. Heuristic approach with combination of two or three primary variables directly resulting from dual-loop data is applied in developing the algorithm to identify the traffic states.

Loop data is capable of resulting in several major variables that may be used to represent the characteristics of traffic streams. For example, those variables include occupancy, speed, and vehicle count. Density can be further estimated based on the estimates of the above variables. Among those variables, vehicle speed and occupancy are observed as stronger indicators of traffic states. Figure 15, illustrates diagrams of the collected samples about the traffic speed, occupancy, and volume vs. time. The sample data is 20-second aggregated data based on the raw event data gained from the sampling dual-loop stations. As a result of statistical analysis of the dual-loop data aligned with the observed traffic states from the concurrent videos, an algorithm for identifying three traffic states, namely, free flow, synchronized flow, and stop-and-go flow, is developed and more details are described below.

3.5.1 Free Flow Identification

According to Kerner's three-phase theory, the free flow traffic has a relatively high and stable average speed and low volume and density or occupancy. Previous studies have proven that the average free flow speeds are often different in different roadways and even different lanes on the same roadway segment. Figure 16 illustrates the speed distribution at the loop station V1002 for lane 2 and lane 3 during a same period of time, respectively (Note: the lane is numbered here from the right to left with integer 1, 2 and 3). The distribution diagrams indicate that the average free flow speed for lane 2 is about 65 mph, and the average free flow speed for lane 3 is about 55 mph. However, the observed difference of average speeds of two consecutive time intervals in the same lane is usually within a certain small range (10 mph in this study with standard deviation of 7 mph with a traffic stream). The algorithm to identify the free flow traffic is expressed as the following:

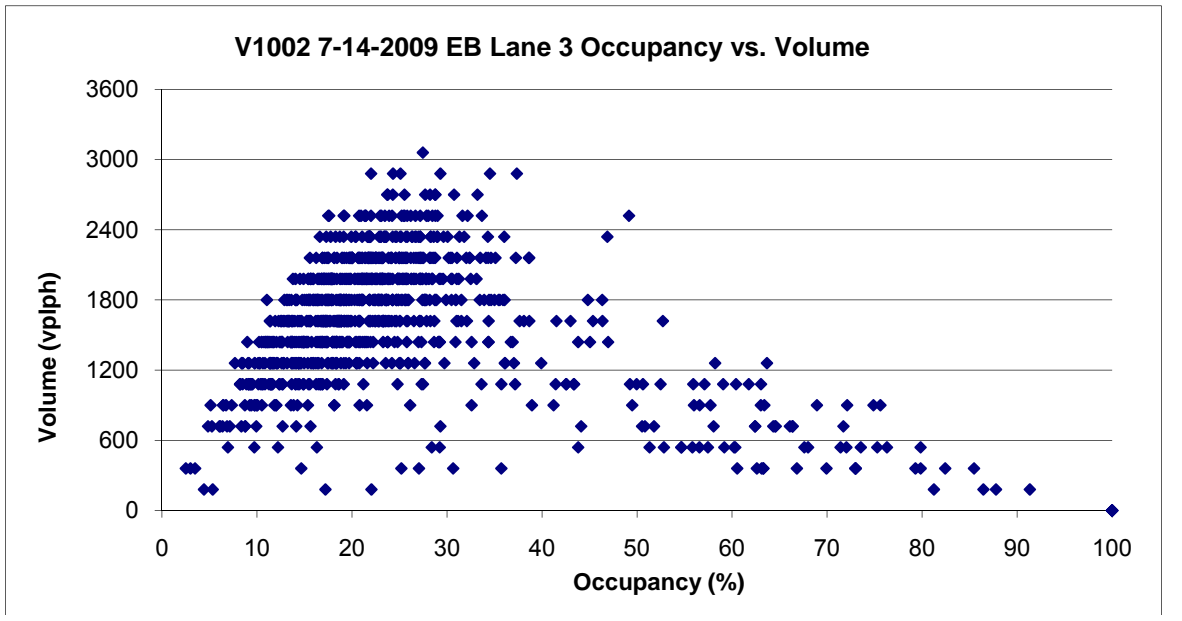
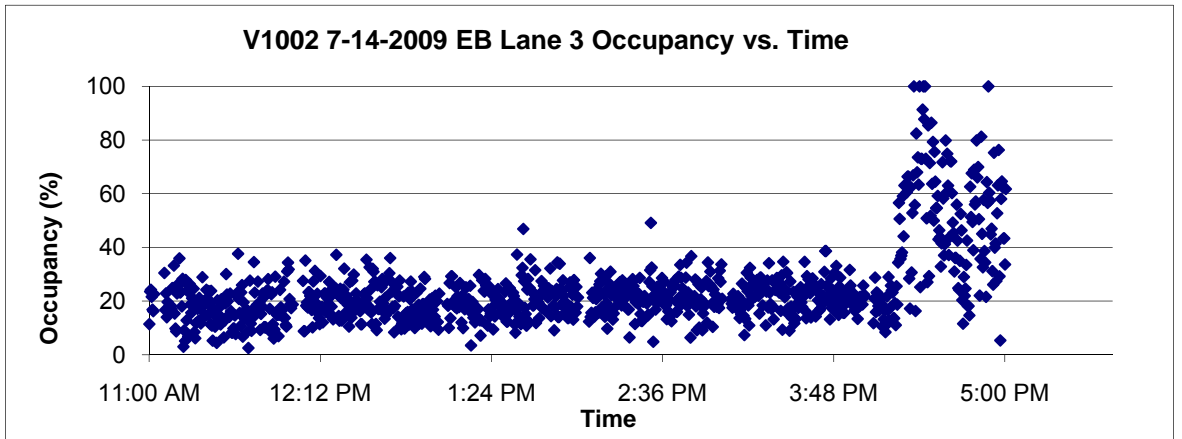
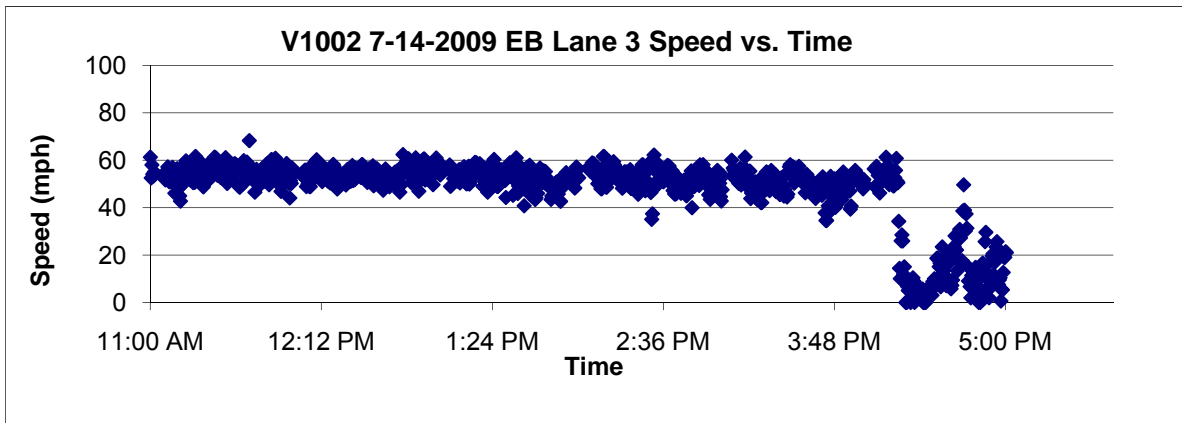

Figure 15. Traffic Speed, Occupancy, and Volume under Different Traffic States

$$\text{If } \bar{v}(t) - \bar{v}(t+1) \leq \Delta v, \text{ and } \text{var}(v) < v^*, \text{ then,} \\ \text{the traffic stream in time interval } t \text{ is free flow.}$$

Where, t is a period of time and in this study $t=5$ min; $\bar{v}(t)$ (mph) is the average speed in time interval t ; $\bar{v}(t+1)$ (mph) is the average speed in the successive time interval $t+1$; $\text{Var}(v)$ is the variation of all vehicles' speed during time interval t ; and Δv , and v^* are predefined threshold of spot speed difference and predefined threshold of the speed variation range in successive time intervals, respectively. Based on statistical analysis of the observed dual-loop data, Δv is defined as 10 mph and v^* is defined as 49 mph^2 (or the standard deviation is 7 mph).

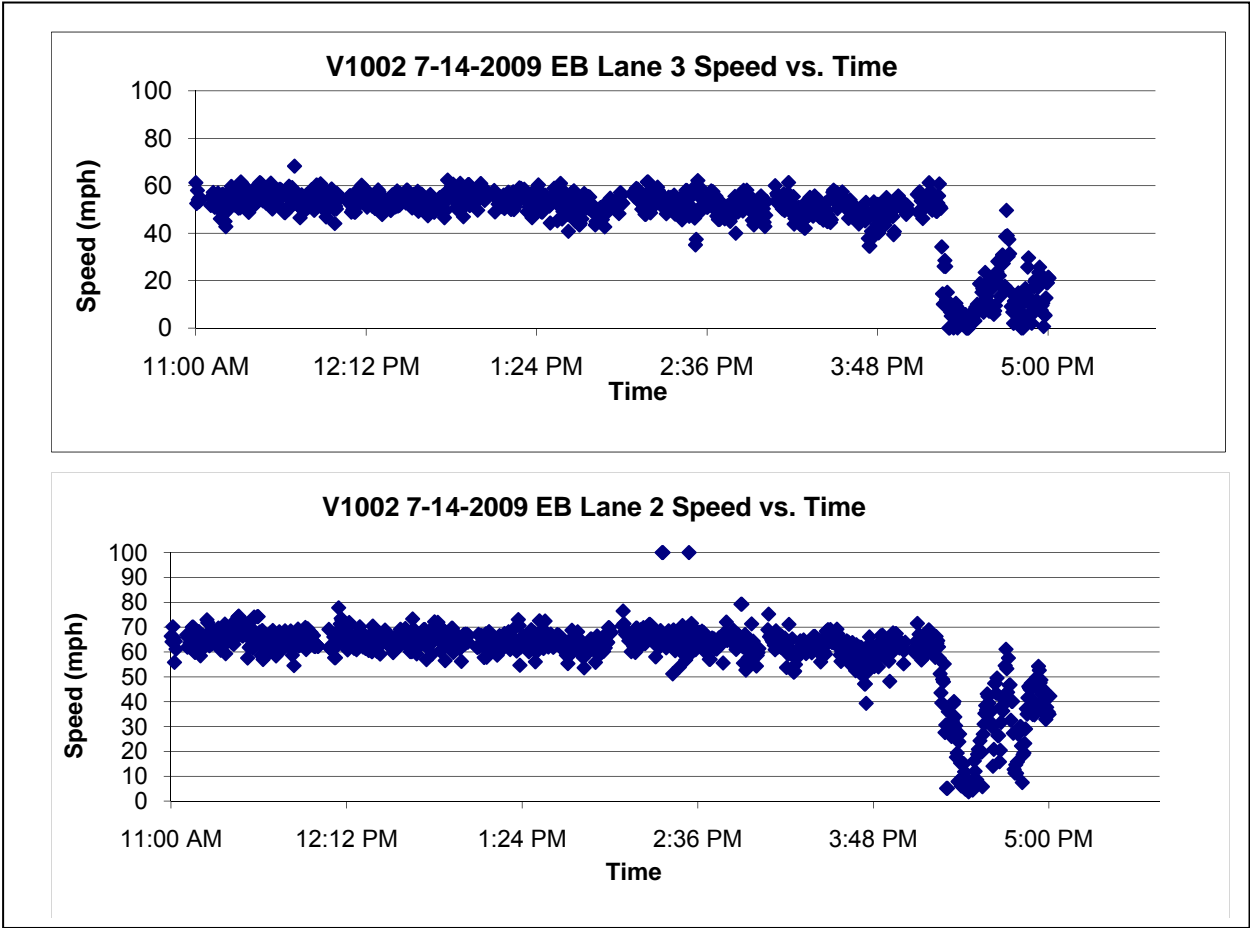

Figure 16. Speed Distributions in Different Lanes

3.5.2 Synchronized traffic identification

The traffic speed of the synchronized flow is relatively low compared with that of the free flow traffic. And the speed is not stable or fluctuates frequently. The traffic volume is larger than the free flow while the occupancy remains stable and without a significant increase. The algorithm for identifying the synchronized traffic is depicted as follows:

If $\bar{v}(t) - \bar{v}(t+1) \leq \Delta v$, and $\text{var}(v) < v^$ are not satisfied, and
If $\overline{occ}(t) - \overline{occ}(t+1) \leq \Delta occ$, and $\overline{occ}(t) < occ^*$, then,
the traffic flow is identified as synchronized traffic flow.*

Where, t is a period of time (5 min in this study); $\overline{occ}(t)$ is the average occupancy during time interval t ; $\overline{occ}(t+1)$ is the average occupancy in the successive time interval $t+1$; and Δocc , and occ^* are the predefined occupancy bandwidth and the maximum average occupancy during the time interval t , respectively. In this study, the threshold of Δocc is defined as 0.3, and occ^* is 0.35.

3.5.3 Stop-and-go traffic identification

The algorithm for identifying the stop-and-go traffic is described as the following:

If both $\bar{v}(t) - \bar{v}(t+1) \leq \Delta v$ and $\text{var}(v) < v^$, and
 $\overline{occ}(t) - \overline{occ}(t+1) \leq \Delta occ$, and $\overline{occ}(t) < occ^*$ are not satisfied, then,
the traffic flow will identified as the stop-and-go traffic flow.*

Based on the above rules, the entire algorithm for identifying the above three different traffic states with dual-loop data is illustrated by Figure 17.

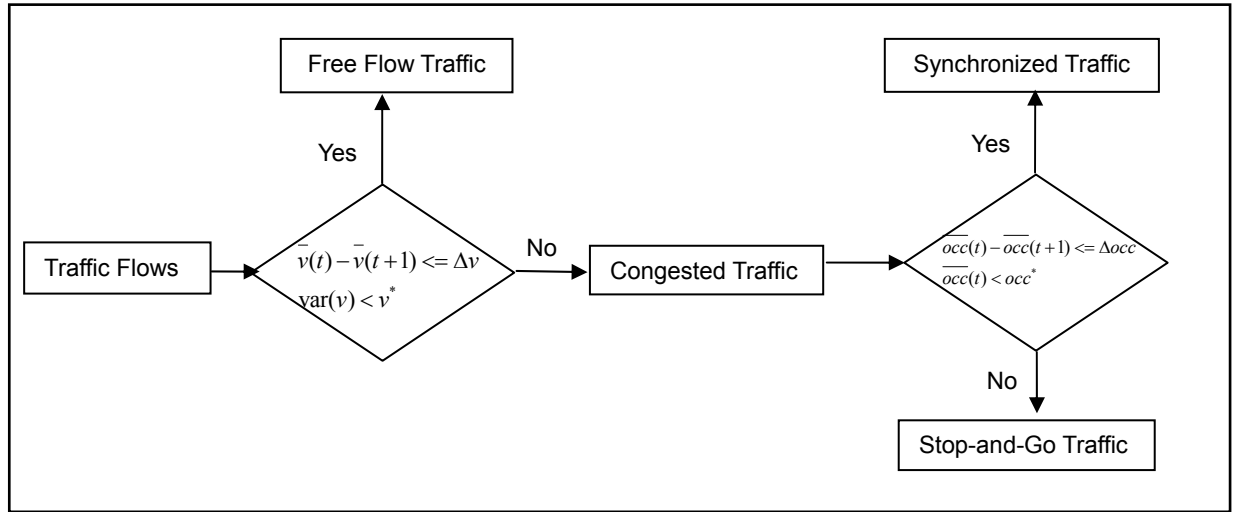

Figure 17. A Flowchart of Identifying Traffic States

3.6 Evaluating the Existing Vehicle Classification Model

Three corrected data sets are used to evaluate the existing length-based vehicle classification model against different traffic states. They are: 902 vehicle samples under free flow traffic, 147 vehicle samples under synchronized traffic, and 61 vehicle samples under stop-and-go traffic. The concurring ground-truth data are used for validation. Under free flow traffic, T-test is used to compare the ground-truth vehicle length data with the vehicle lengths estimated by using existing models based on the concurrent loop data. The sample sizes of two data sets are 902, respectively. The hypothesis is set up assuming that the two variables have the same mean but different variances. According to the T-test result, the t value = 0.7734, which is less than the *critical t value* = 1.96 with confidence level of 95%. So, the hypothesis can be accepted that the two variables have the same mean value. In other words, the result confirms that the existing model is suitable for free flow condition.

3.7 Developing New Vehicle Classification Model under Synchronized Flow

Under the synchronized traffic flow condition, the travel speed of the traffic flow is lower than that of the free flow, and higher than that of the stop-and-go flow. The thresholds of identifying synchronized traffic flow have been discussed in Section 3.5.2. As mentioned earlier, the vehicles possibly run over the upstream and downstream loops at different speeds within the synchronized traffic flow. Acceleration or deceleration may hence play an influential role in measuring the vehicle length. In the proposed Vehicle Classification under Synchronized Traffic Model (VC-Sync model), vehicles' acceleration or deceleration is considered as one of contributing factors. If a vehicle passes the dual-loop detectors area at a stable acceleration or deceleration rate (without a stop), the VC-Sync model is expressed by the following equations:

$$L_v = v_0 \cdot OnT_1 + \frac{1}{2} a(OnT_1)^2 - L_s \quad (7)$$

$$v_0 = \frac{D}{t} - \frac{a \cdot t}{2} \quad (8)$$

$$a = \frac{D}{t} \left[\frac{2 \cdot (OnT_1 - OnT_2)}{(OnT_2)^2 - (OnT_1)^2 + (OnT_1 + OnT_2) \cdot t} \right] \quad (9)$$

Where,

L_v = length of the detected vehicle (ft);

L_s = length of each single loop within the dual-loop (ft);

v_0 = speed of the vehicle entering the upstream loop (M loop) (ft/s);

a = vehicle acceleration (ft/s²); and

D , t , OnT_1 , and OnT_2 are the same as defined earlier in the paper (see Figure 1).

Figure 18 shows the results of comparing the sample vehicle lengths that are estimated by the existing model and by the VC-Sync model, respectively. Compared to the ground-truth data, the error of the existing model is 35.2%, and the error of the VC-Sync model is 8.5%. This result indicates that the developed VC-Sync model greatly improves the accuracy of vehicle classification under the synchronized flow condition.

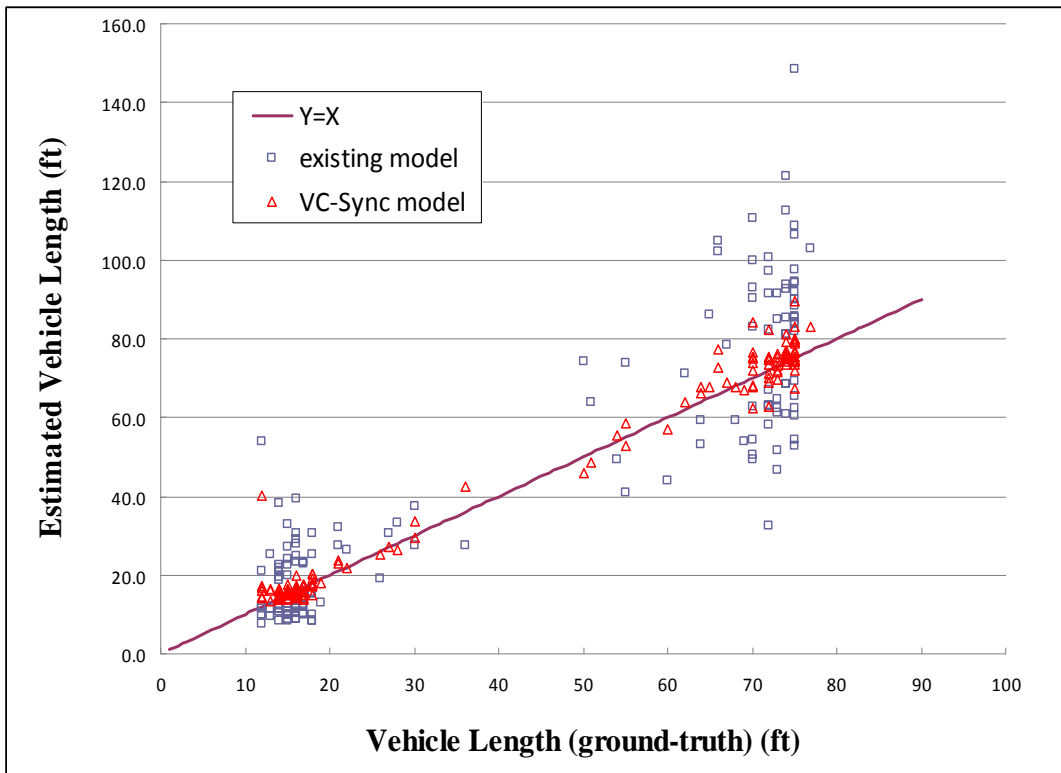

Figure 18. Estimated Vehicle Lengths under Synchronized Traffic

Table 6. Vehicle Assignment during Synchronized Traffic (3-Bin Scheme)

By Ground-truth Data		By Dual-loop Data (note: *correct identification)				
Bins	# of Vehicles	Bin type identified by vehicle length	# of vehicles by existing model	%	# of vehicles by VC-Sync model	%
Bin 1	73	*Bin 1	63	86%	72	99%
		Bin 2	9	12%	1	1%
		Bin 3	1	1%	0	0
Bin 2	3	Bin 1	2	67%	0	0
		*Bin 2	1	33%	3	100%
		Bin 3	0	0	0	0
Bin 3	71	Bin 1	0	0	0	0
		Bin 2	3	4%	1	1%
		*Bin 3	68	96%	70	99%

Table 7. Vehicle Assignment during Synchronized Traffic (4-Bins Scheme)

By Ground-truth Data		By Dual-loop Data (note: *correct identification)				
Bins	# of Vehicles	Bin type identified by vehicle length	# of vehicles by existing model	%	# of vehicles by VC-Sync model	%
Bin 1	71	*Bin 1	59	83%	70	99%
		Bin 2	11	15%	0	0%
		Bin 3	1	1%	1	1%
		Bin 4	0	0%	0	0%
Bin 2	5	Bin 1	0	0%	0	0%
		*Bin 2	5	100%	4	80%
		Bin 3	0	0%	1	20%
		Bin 4	0	0%	0	0%
Bin 3	10	Bin 1	0	0%	0	0%
		Bin 2	0	0%	0	0%
		*Bin 3	6	60%	7	70%
		Bin 4	4	40%	3	30%
Bin 4	61	Bin 1	0	0%	0	0%
		Bin 2	1	2%	0	0%
		Bin 3	20	33%	2	3%
		*Bin 4	40	66%	59	97%

Table 6 shows the comparison of the outcomes resulted from the existing model and VC-Sync model based on 3-bin and 4-bin schemes. As mentioned earlier, the 3-bin scheme is currently used by ODOT and the 4-bin scheme is used by WSDOT. As shown in Table 6, the

existing model results in 13% of vehicles of Bin 1 which are misidentified as vehicles of Bin 2 and Bin 3. 67% of vehicles of Bin 2 are mistaken as vehicles of Bin 1. The accuracy for Bin 3 is good (97%). When the VC-Sync model is used, the accuracy of Bin 2 is improved to 100% while there is only 1% vehicle of Bin 1 which is misidentified as Bin 2. For the 4-bin scheme, VC-Sync model has resulted in a significant improvement in the accuracy of vehicle classification. As shown in Table 7, the accuracy for Bin 1 has been improved from 83% to 99%, and that for Bin 4 has been improved from 66% to 97%.

3.8 Developing New Vehicle Classification Model under Stop-and-go Traffic

3.8.1 Scenarios of Vehicle Stopping Status

Under the stop-and-go traffic state, a vehicle may stop within the detection area for at least one time. The thresholds of identifying stop-and-go traffic flow have been discussed in Section 3.5.3. The Vehicle Classification under Stop-and-Go Model (VC-Stog model) is developed to estimate vehicle length under the stop-and-go traffic condition. To facilitate the modeling, eight scenarios are developed depending on the stopping locations of the detected vehicle within the detection area, as shown by Figure 19. Different sub-models are developed compatible with those scenarios as defined as follows:

Scenario 1: the vehicle runs across the loops without stop;

Scenario 2: the vehicle stops only on the M loop;

Scenario 3: the vehicle stops only on the S loop;

Scenario 4: the vehicle stops only on both the M and S loops;

Scenario 5: the vehicle stops on M loop and then move on, then stop on S loop;

Scenario 6: the vehicle stops only on the M loop, and then stops on both the M and S loops;

Scenario 7: the vehicle stops on both of the M and S loops, and then stops only on S loop; and

Scenario 8: the vehicle stops only on the M loop and then stops on both of the M and S loop, and finally stops only on the S loop.

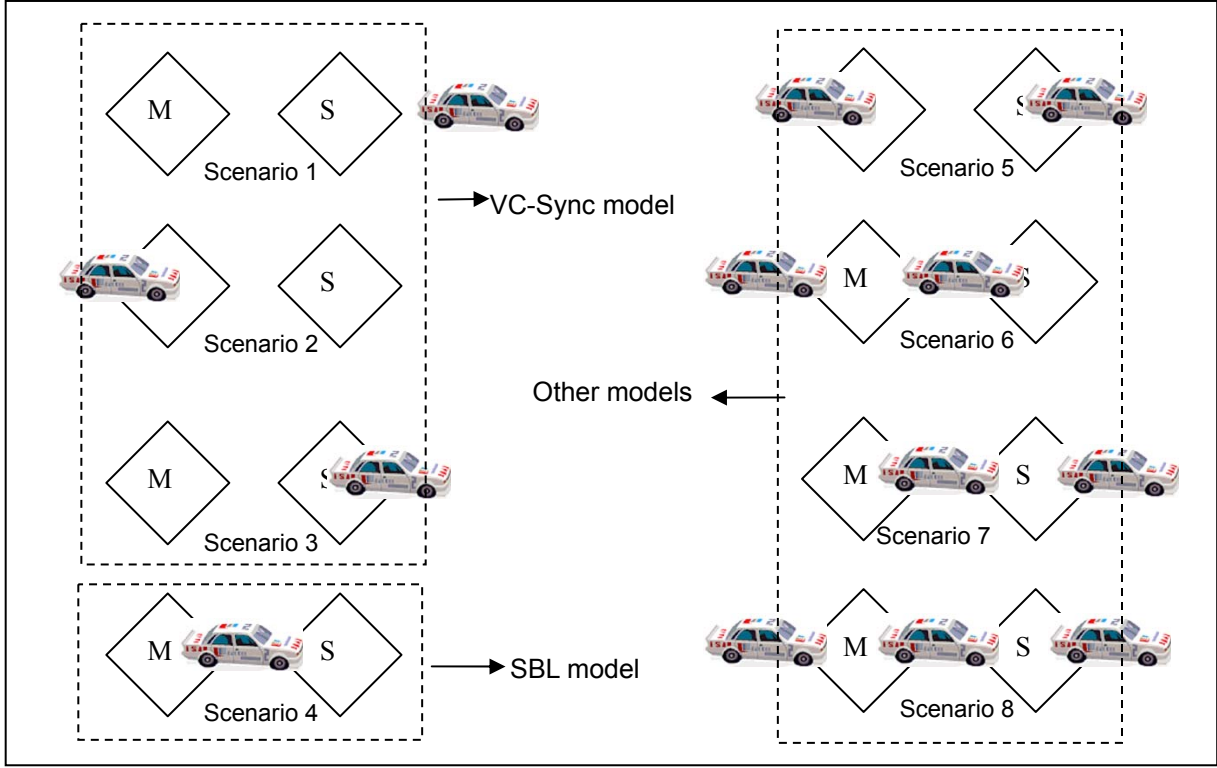

Figure 19. Different Scenarios of Vehicle Stopping on Loops under Stop-and-go Flow

3.8.2 Developing Length-based Vehicle Classification against Stop-and-Go Traffic

The VC-Stog model is comprised of several sub-models which deal with different scenarios. For Scenario 1, the vehicle does not stop, so it can be also treated in case of synchronized traffic and the VC-Sync model is applied to this case. Based on the theoretical calculation, Scenarios 2 is approximately equivalent to the situation in which the vehicle just stops at the front edge of the M loop and then leaves the detection area without stopping. Similarly, Scenarios 3 is similar to the situation in which the vehicle just stops at the rear edge of the S loop. Thus, the VC-Sync model is also suitable to Scenarios 2 and 3. A **S**top-on-**B**oth-**L**oops-only (SBL) model is developed for Scenario 4. For Scenario 4 it is assumed that the vehicle stops in the middle between the two single loops. After stopping a period of t_s it starts to move again with the acceleration rate a , and then leaves the loop station area. The SBL model is expressed by the following equations:

$$L_v = f_1 \cdot t_{dec} \cdot D \cdot \frac{1}{t} + \frac{1}{2} f_2 \cdot a \cdot t_{acc}^2 - L_s \quad (10)$$

$$t_{dec} + t_{acc} = OnT_1 - t_s \quad (11)$$

$$t_s = t_2 - t_3 - f_3 \frac{t_{acc}^2}{v_{min}} \quad (12)$$

Where,

L_v = length of vehicle (ft);

L_s = length of each single loop within the dual-loop (ft);

t_{dec} = time period from a vehicle entering the M loop to its stop (s);

t_{acc} = time period from a vehicle starting to move to leaving the M loop (s);

a = the average acceleration rate of of vehicles when they start to move under stop-and-go traffic (ft/s²);

t_s = time period for a vehicle stopping on both loops (s);

v_{min} = the minimum speed which can maintain a vehicle running without stop (ft/s);

$f_1, f_2, \text{ and } f_3$ = adjusting factors for different vehicle types (in this study, $f_1 = f_2 = f_3 = 1$);

$D, t, t_2, t_3, OnT_1, \text{ and } OnT_2$ = as the same as defined previously.

In order to estimate vehicle lengths by this SBL model, it is necessary to determine the vehicle's acceleration rate (a) and the time period for a vehicle stopping on both of the loops (t_s). As mentioned earlier, the GPS data can be used to reveal the vehicle's speeds and changes of speeds during at very short time intervals. In order to quantify these parameters, the GPS data gained within stop-and-go traffic flows is employed to set up the acceleration rate a through statistical analysis. The minimum speed v_{min} is defined as the speed that a vehicle can maintain during the course of the "go" state in the stop-and-go stream. Based on the statistical analysis of the dual-loop data under stop-and-go traffic, the thresholds as shown in Figure 20, t_{s1} and t_{s2} are determined as: $t_{s1} = 4.1s$, and $t_{s2} = 3.0s$. Among the 61 sample vehicles with stop-and-go traffic, there are 35 sample vehicles falling into the Scenario 4 and 26 sample vehicles in the Scenarios 2 and 3. Among the 35 sample vehicles, 25 sample vehicles are used to calibrate the SBL model. The rest of the 10 sample vehicles are used to validate the SBL model. Using the GPS data and the model calibration, the factors involved in the SBL model are determined as follows:

- The average vehicle acceleration rate is determined as 2.5 ft/s².
- The minimum speed v_{min} is determined as 7 ft/s (4.77 miles/hour).

Scenarios 5, 6, 7, and 8 are more complicated. Each of these scenarios can be considered as the combination of 2 or more scenarios of scenarios 1-4. The models for scenario 5, 6, 7, and 8 will be developed in the future research plan.

Figure 21 shows the estimated the lengths of stop-and-go vehicles by using the existing model and the VC-Stog model (i.e. VC-Sync model + SBL model), respectively. Compared to the ground-truth data, the relative error of the estimated vehicle lengths resulted from the existing model is 210%, while the relative error of those resulted from the VC-Stog model is 27.7%. Although the error of 27.7% remains unsatisfactory, a significant improvement has been achieved comparing to the error of 210% by the existing model.

In the meanwhile, the 3-bin scheme is investigated using the outcomes resulting from the existing model and the VC-Stog model, respectively. Table 8 shows the result for the 3-bin scheme. There are 58% vehicles of Bin 1 which are misidentified as Bin 2 or Bin 3 by the existing model, and 15% vehicles of Bin 3 are mistaken as Bin 1 or Bin 2. With use of the

VC-Stog model (which includes the VC-Sync model and the SBL model), the accuracies for vehicles of Bin 1 and Bin 3 have been improved to 92% and 91%, respectively.

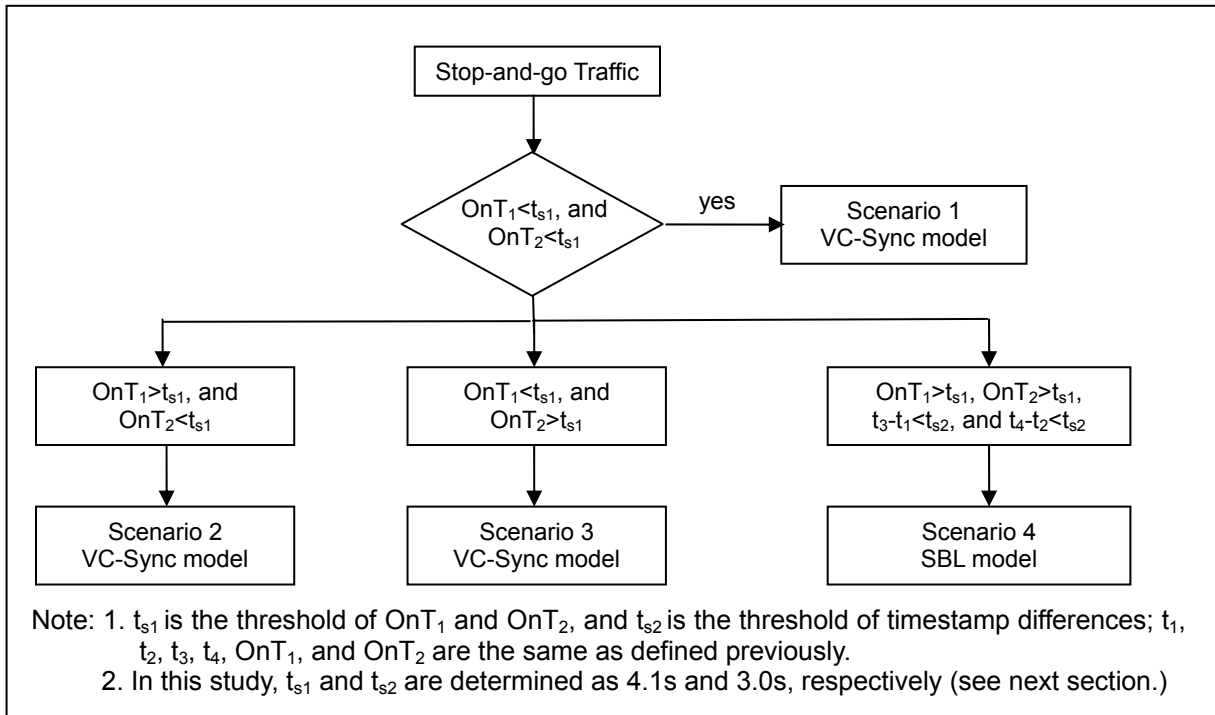

Figure 20. A Flowchart for Identifying Vehicle Stopping Status

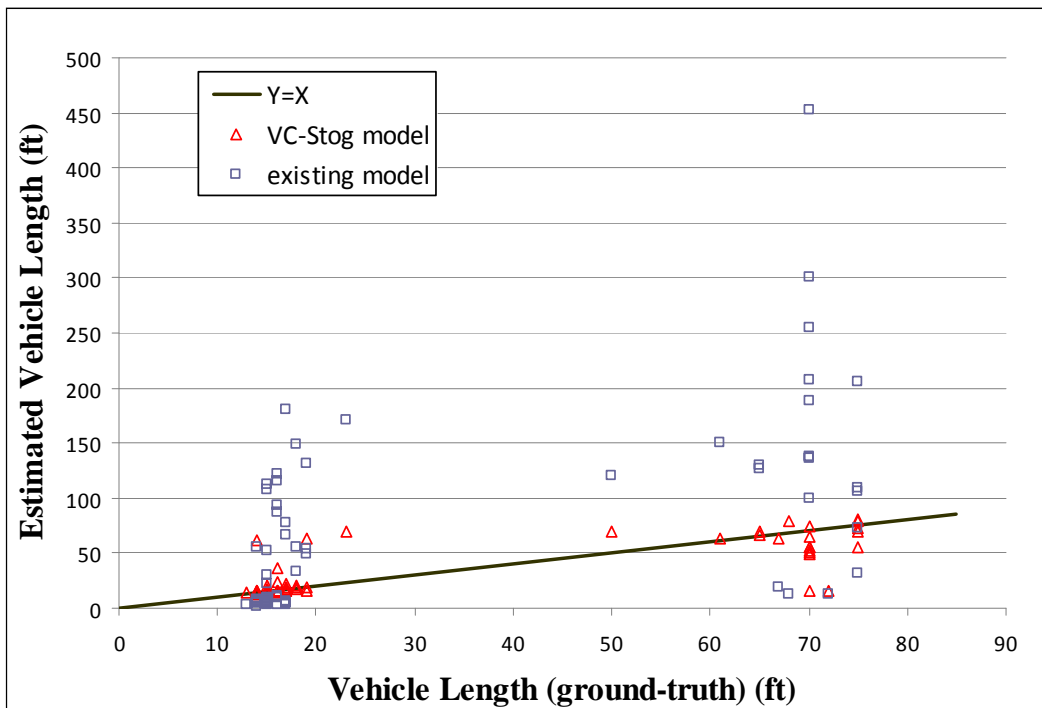

Figure 21. Estimated Vehicle Lengths under Stop-and-go Traffic

Table 8. Vehicle Assignment during Stop-and-go Traffic (3-Bin Scheme)

By Ground-truth Data		By Dual-Loop Data (note: *correct identification)				
Bins	# of Vehicles	Bin type identified by vehicle length	# of vehicles by existing model	%	# of vehicles by VC-Stog model	%
Bin 1	39	<i>*Bin 1</i>	17	43%	36	92%
		Bin 2	4	11%	0	0%
		Bin 3	18	47%	3	8%
Bin 2	0	Bin 1	0	N/A	0	N/A
		<i>*Bin 2</i>	0	N/A	0	N/A
		Bin 3	0	N/A	0	N/A
Bin 3	22	Bin 1	2	11%	2	9%
		Bin 2	1	4%	0	0%
		<i>*Bin 3</i>	19	85%	20	91%

CHAPTER 4: LOOP DETECTOR LAYOUTS ADOPTED BY VARIOUS STATE DOTs

The loop detector standards, layouts and installation methods were collected from 17 states: California, Connecticut, Florida, Illinois, Indiana, Maryland, Massachusetts, Michigan, Mississippi, Montana, New Jersey, New York, Oregon, Pennsylvania, Texas, Utah, and Washington.

4.1 State of California

4.1.1 Specification

For measuring speed, the loops should be large enough to sense high-body vehicles and provide a sharply defined wave front output as the vehicle passes over the loop. Any time differences in detecting different vehicle types passing over the loops should be minimized. The loops should be spaced sufficiently far apart so that any difference in the time of intercept of the two inductive-loop detectors is small as compared to the transit time from the first to the second loop.

A rule of thumb for loop design states that the height of the magnetic field intercepted by the vehicle is two-thirds the distance of the shorter loop dimension. A 6- x 6-ft (1.8- x 1.8-m) or a 6- x 100-ft (1.8- x 30.5-m) loop has intercepts of approximately 4 ft (1.2 m). Both 5-ft (1.5-m) wide and 6-ft (1.8 m) wide loops have proven effective at consistently detecting high-body vehicles. The choice depends on lane width. A spacing of at least 2.5 ft (0.8 m) should be allowed from the centerline to the edge of the loop to avoid actuation by traffic in adjacent lanes. In a 12-ft (3.6-m) lane, the 6-ft (1.8-m) loop should be used to ensure no counts are missed.

The spacing between loops for speed measurements is often specified as 16 ft (4.9 m) between the leading edges of two 6-ft (1.8-m) loops. The sensitivity of the electronics unit connected to each loop must be the same. Otherwise, the critical change in loop inductance needed to activate the electronics unit, which is proportional to the sensitivity, will vary from loop to loop, thereby introducing a measurement error. Advance detectors should be considered in the main street, and also on the side street if the vehicle speed is 30 mph or greater. Advance detectors should have a separate detector lead-in cable (DLC) per loop designation and should be located as shown in Figure 22 (for speeds between the values shown, use the next higher value):

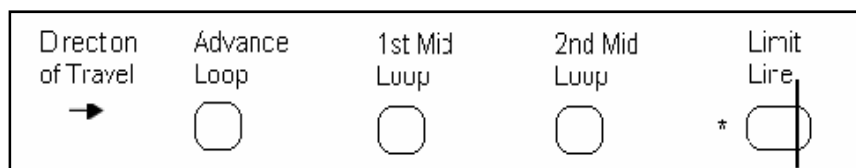

Figure 22. Advance and Mid Loop Detectors

* Front Detection type/location per District guidelines

Table 9. California’s Speed and Loop Distance for Advance Detection Guidelines

Approach Speed, mph	Distance of Advance Loop from Limit Line, ft*	Distance of Intermediate Loop from Limit Line, Ft	
		1 st Mid Loop	2 nd Mid Loop
25	105**		
30	140		
35	185		
40	230	113**	
45	285	153	
50	345	198	
55	405	244	83**
60***	475	300	125
65***	550	359	168
70***	630	425	220

* Per Chapter 4D, California MUTCD; ** Intermediate loop may or may not be needed, consult the Electrical Design Branch Chief; *** Two mid detector loops per lane are recommended.

4.1.2 Automatic Vehicle Classification Station

Automatic Vehicle Classification (AVC) System mainly consists of AVC unit including modem, antenna assembly, type “M” cabinet, inductive loop detector, piezo-electric axle sensors, pull boxes, conduits and conductors. Piezo-electric axle sensors include a screened transmission cable. The sensors should be installed in an array of one inductive loop detector and two axle sensors per lane. For typical AVC layout, see Figure 23 below.

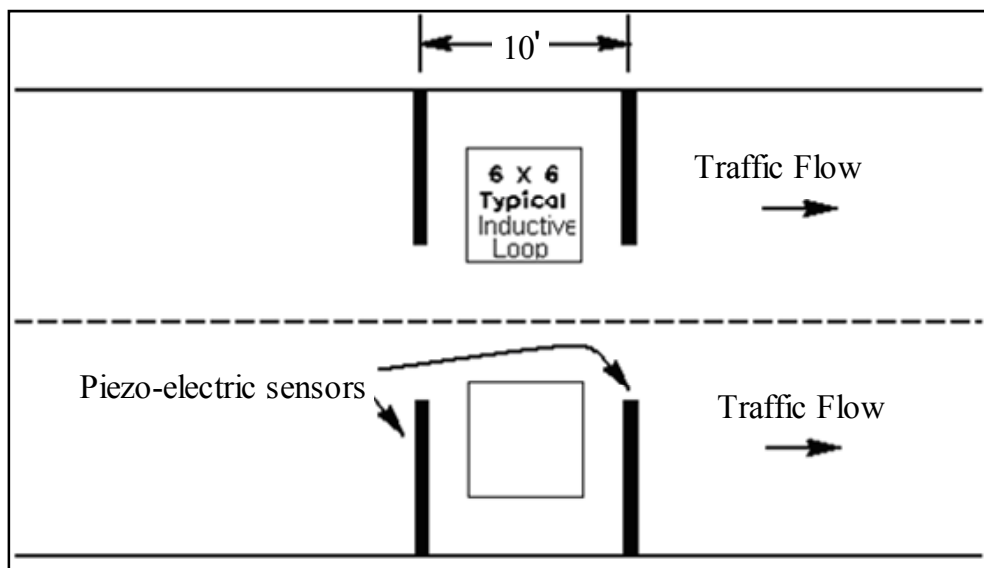

Figure 23. Piezo-electric Sensors

4.2 State of Connecticut

Connecticut DOT's loop detector installation standards are as described below:

- Shall comply with National Electrical Manufacturers Association (NEMA) standards, Section 6.5, Inductive Loop Detectors.
- Shall comply with the current Connecticut DOT Functional Specifications for Traffic Control Equipment, Section 3 B: "Loop Vehicle Detector with Delay/Extend Option" which is summarized below.

4.2.1 Functional Requirements

The loop detector shall be an electronic device, capable of detecting the presence of a moving or parked vehicle; and the detection shall be accomplished by the presence of a parked or moving vehicle over a wire loop embedded in the roadway.

Loop Frequency: The detector shall be capable of selecting various operating frequencies by changing switch positions located on the front of the amplifier.

Sensitivity: Additional switches located on the front panel shall be capable of changing the sensitivity of the amplifier to compensate any loop/lead network and provide for an ideal operating range. It shall be possible to select a minimum of the following modes of operation which shall function as follows:

- *Mode 1 - Pulse Detection* - The detector sensing unit shall detect a vehicle as slow as 0.1609 kilometers per hour (1/10 mph) entering the loop. If a vehicle stops over a portion of the loop such as waiting for a left turn, the remaining portion of the loop shall detect additional vehicles passing over the unoccupied portion of the loop. The time for the remaining portion of the loop to become capable of detecting additional vehicles shall be no longer than the minimum time it takes for the next vehicle to pass over the loop.
- *Mode 2 - Long Detection* - The detector sensing unit shall detect a vehicle as slow as 0.1609 kilometers per hour (1/10 mph) entering the loop. When a vehicle remains over the loop or a portion thereof, the detector sensing unit shall cause detection to persist up to at least 10 minutes. After this period any vehicle passing over the unoccupied portion of the loop shall be detected.

4.2.3 Electrical Requirements

The detector sensing unit shall operate on 115 volts, 60 cycles A.C. and shall draw not more than 15 Watts. The unit shall contain an integral regulated power supply which will operate independent of line voltage variations between 100 and 135. The power supply shall be regulated by zener reference and series regulation and shall be fused. The detector shall operate properly at all temperatures between -34.44°C and 65.55°C (-30°F. and +150°F). An automatic frequency control feature and an automatic equalization feature shall be included in the detector to

compensate for long term drift due to environmental changes. The detector shall be solid state with the exception of the output relay.

4.2.4 Mechanical Requirements

The detector shall be housed in a durable finished fabricated sheet aluminum case. No special tool shall be required for removal of the cover. Removal of the cover shall provide access to the entire circuit and all components while the unit is connected and operating. The electrical connections of both the incoming and outgoing circuits shall be made by means of a suitable multi pin plug. The entire unit shall be replaced with a similar unit without the necessity of disconnecting and reconnecting individual wires leading there from. The plug receptacle shall be attached to one end of a connecting cable (included with the unit) at least 1829 mm (72 inches) long. The plug connector shall not have split pins that can be spread apart during amplifier cable installation causing connection problems. The cable shall be color coded as shown and all wires within the cable shall be a minimum # 22 A.W.G. stranded. The cable shall come with a preinstalled wiring harness cover for protection (loom type). A switch mounted on the front of the detector unit shall be provided for selecting the mode of operation to be in effect. Also mounted on the front of the detector will be an indicator light which will register vehicle actuations.

4.2.5 Delay Operation

Delays output until vehicle presence has been sustained for the time selected. Call delay shall start counting when a vehicle enters the loop detection zone, and shall reset with each gap. Whenever a phase green input (pin j “Timer override”) signal is active, (110 vac) timing shall be aborted and the call delay timer forced to zero. Timing range shall be 0 - 31 seconds in one second increments.

4.2.6 Extended Operations

Extends output for the time selected after the vehicle leaves the loop. Call extension shall start counting when a vehicle leaves the detection zone, and shall reset with each detection. Timing range shall be 0 - 15.5 in 1/2 second increments.

4.2.7 Loop Detector Saw Cut

- Loop size, number of turns, and location shall be as shown on the intersection plan.
- Do not cut through a patched trench, damaged or poor quality pavement without the approval of the Engineer.
- Wet-cut pavement with a power saw using a diamond blade $\frac{3}{8}$ inch (9.5mm) wide. Dry-cut only with the approval of the Engineer.
- Ensure slot depth is between 1 $\frac{3}{4}$ inch to 2.0 inch (45mm to 50mm).
- Overlap corners to ensure full depth of cut.

- To prevent wire kinking and insulation damage, chamfer inside of corners that are ≤ 120 degrees.
- Clean all cutting residue and moisture from slot with oil-free compressed air. Ensure slot is dry before inserting wire and sealing saw cut.
- Cut home-run, from loop to curb or edge-of-road, as shown on the typical installation sheet.
- To prevent cross-talk and minimize electrical interference, twist home-run wires, from edge of road to handhole, with at least 5 turns per foot (16 turns per meter). Tape together twisted home-run wires at 2 foot (0.6 meter) \pm intervals.
- In new or resurfaced pavement, install loops in the wearing course. If the wearing course is not scheduled for immediate placement (within 24 hours) after the base course, provide temporary detection. Temporary detection may be saw cut loops, preformed loops, microwave sensor, video, or other method approved by the Engineer.
- Splice(s) not allowed anywhere in loop wire either in loop or in home-run.
- Ensure wires are held in place at bottom of slot by inserting at 2 foot (0.6 m) intervals, 1 inch sections of foam backer rod or wedges formed from 1 inch (25mm) sections of the polyethylene tubing. Loop detectors with wires that have floated to the top of the sealant will not be accepted.
- To create a uniform magnetic field in the detection zone, wind adjacent loops in opposite directions.
- Use *polyester compound* as the sealant unless another type is allowed by the Engineer.
- Mix hardening agent into polyester resin with a power mixer or in an application machine designed for this type of sealant in accordance with the manufacturer's instructions.
- Apply the loop sealant in accordance with the manufacturer's instructions and the typical installation sheet. Do not apply sealant when pavement temperature is outside the manufacturers recommended application range.
- Solder splice the loop wires to the lead-in cable and install water resistant connector as shown on the typical installation sheet.
- Test the loop circuit resistance, inductance, and amplifier power-interruption as shown on the typical installation sheet. Document all test results.

4.3 State of Florida

4.3.1 Materials

Use inductive loop detectors, pre-formed loop assemblies and loop sealant currently listed on the Department's Approved Products List (APL). Ensure that all loop detectors are marked in accordance with Section 603 and the markings are visible after installation.

4.3.2 Installation Requirements

Inductive Loop-Detector Units: Install inductive loop detector units and cable harnesses in accordance with the manufacturer's instructions and the Design Standards, Index No. 17781. Adjust the operating frequency of each detector unit, if required, to prevent crosstalk of the units.

Saw Cuts: Use a chalk line or equivalent method to outline the perimeter of the loop on the pavement and routes for lead-in cables. Do not allow the saw cut in the pavement to deviate by more than 1 inch from the chalked line. Ensure that all saw cuts are free of any dust, dirt or other debris and completely dry prior to the installation of the loop wire, loop wire twisted pair lead or lead-in cable. Make saw cuts in accordance with the Design Standards, Index No. 17781. Ensure that the top conductor of the loop wire or lead-in cable is a minimum of 1 inch below the final surface of the roadway.

Loop Wire: Ensure that all loops are wound in a clockwise manner and the first turn of the loop wire is placed in the bottom of the saw cut, with each subsequent turn placed on top of the preceding turn. Push the loop wire to the bottom of the saw cut with a non-metallic tool which will not damage the insulation.

Tag and identify the clockwise “lead” of each loop. Use alternate polarity on adjacent loops. Ensure that the hold down material is non-metallic and is not longer than 1 inch and that the distance from the top of the hold down material to the final surface of the roadway is not less than 3/4 inch. Twist the loop wire a minimum of five turns per 1 foot to form a loop wire twisted pair lead from the edge of the loop to the pull box.

Splice the loop wire twisted pair lead to the lead-in cable in the pull box. Place only one loop wire twisted pair lead in a saw cut. Ensure that the distance between a twisted loop wire pair lead within the roadway is a minimum of 6 inches from any other twisted loop wire pair lead or loop, until they are within 1 foot of the edge of pavement or curb, at which point they may be placed closer together. Prepare and apply the loop sealant in accordance with the manufacturer’s instructions. Ensure that the loop sealant has cured completely before allowing vehicular traffic to travel over the sealant.

Lead-In Cable: Place the lead-in cable in the bottom of the saw cut. Do not damage the insulation. Install no more than four lead-in cables in a saw cut. Ensure that the hold down material is not longer than 1 inch and that the distance from the top of the hold down material to the final surface of the roadway is not less than 3/4 inch. Prepare and apply the loop sealant in accordance with the manufacturer’s instructions. Ensure that the loop sealant has cured completely before allowing vehicular traffic to travel over the sealant.

Figure 24 shows the Florida standard vehicle loop detector detail drawings based on Design Standard Index No. 17781. FDOT suggests the following steps when installing loop detectors:

- If the loop lead-in is 75" or less from the edge of the loop detector to controller cabinet, continue the twisted pair to the cabinet. If the loop lead-in is greater than 75" continue the twisted pair to the specified pullbox, splice to shielded lead-in wire and continue to the controller cabinet.
- The width of all cuts shall be sufficient to allow unforced placement of loop wire or lead-in cables into the saw cuts. The depth of all saw cuts, except across expansion joints, shall be 3" standard with a maximum of 4".

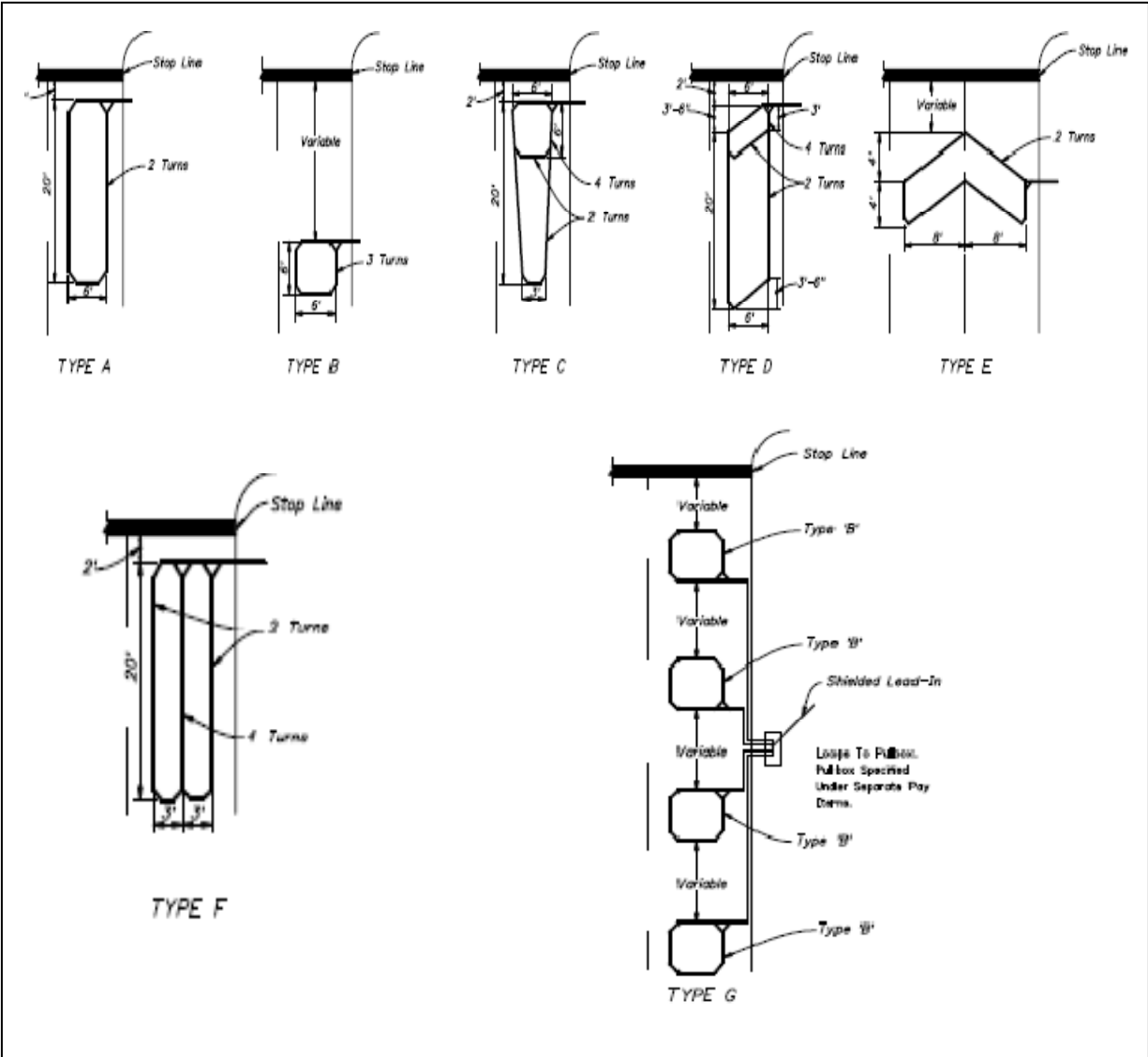

Figure 24. Florida Standard Vehicle loop Installation Details

- On resurfacing or new roadway construction projects, the loop wire and lead-in cables may be installed in the asphalt structural course prior to the placement of final asphalt wearing course. The loop wire and lead-in cables shall be placed in a saw cut in the structural course. The depth of the cables below the top of the final surface shall comply with note (b) above.
- A nonmetallic hold down material shall be used to secure loop wires and lead-ins to the bottom of the saw-cuts. Hold down material shall be placed at approximately 12" intervals around the loops and 24" intervals on lead-ins.
- The minimum distance between the twisted pairs of the loop lead-in wire is 6" from the loop to 12" from the pavement edge or curb.

- Splice connections in pull boxes with UL listed, watertight, insulated enclosures. Place one enclosure over the end of each conductor and place a third enclosure over the exposed end of the shielded cable.
- As an alternate, a larger diameter enclosure that will accommodate both the splices of the conductors and the exposed end of the shielded cable may be used.
- The maximum area of asphalt to be disturbed shall be 6" x 6". This area shall be restored as directed by the Engineer.

4.4 State of Illinois

The typical layouts for detection loops and their wiring systems of the Illinois Department of Transportation (IDOT) are shown in Figures 25 and 26. **Error! Reference source not found.** Short loops for point detection shall be 6' wide x 6' long and the long loops for presence detection shall be 6' wide x up to 50' long. Figure 25 depicts the IDOT's standard loop detector installation details.

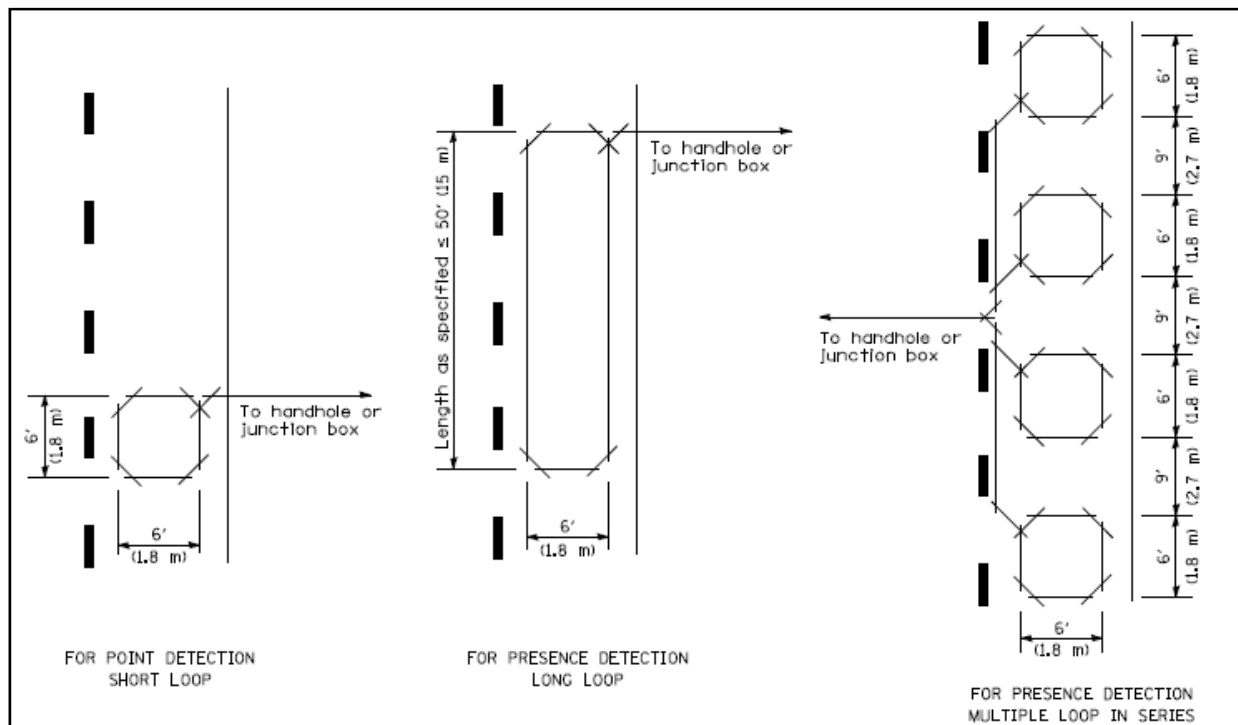

Figure 25. IDOT Typical Layout for Detection Loops

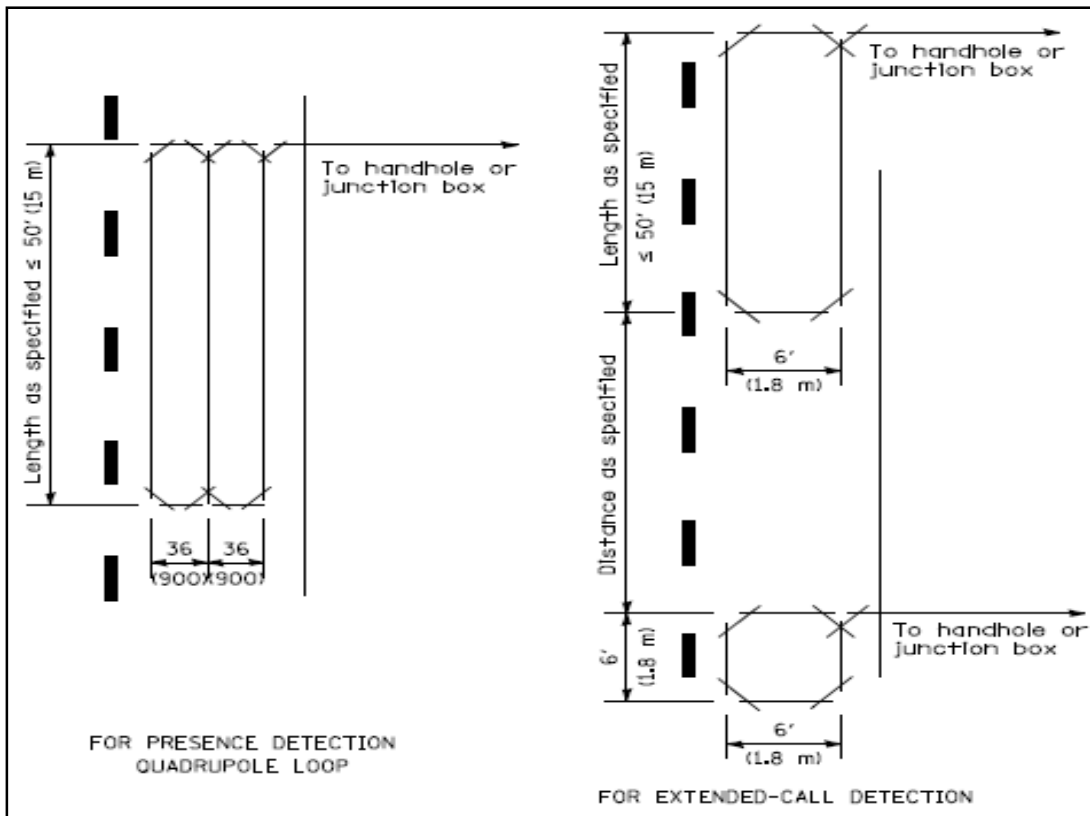

Figure 26. IDOT Typical Layout for Detection Loops

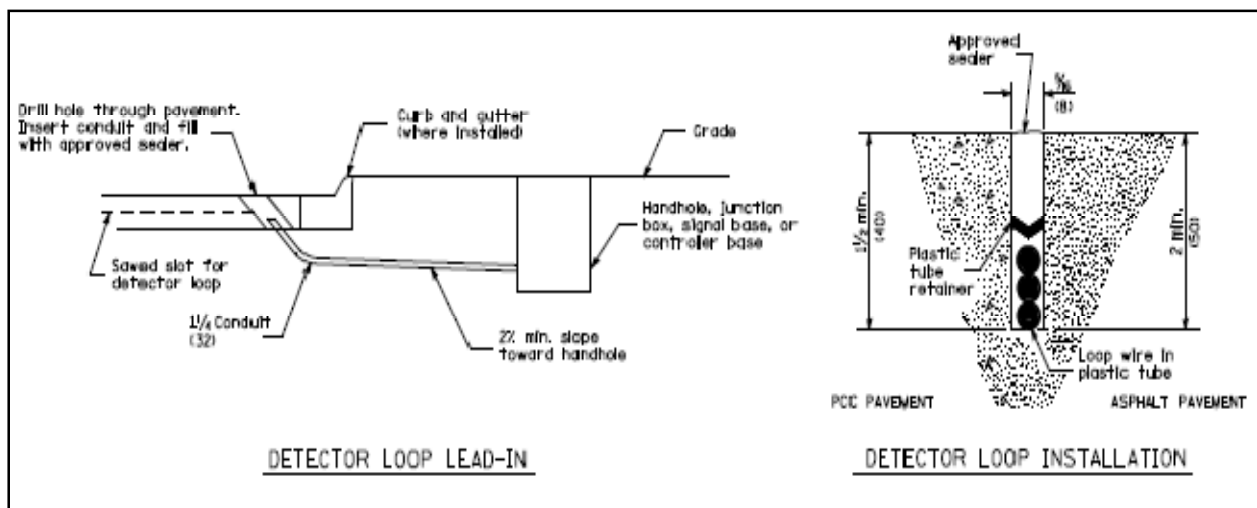

Figure 27. IDOT's Detector Loop Installation Details

4.5 State of Indiana

Indiana Department of Transportation (INDOT) uses induction loops, microloops, and magnetimeters as primary detection. The following specifications describe INDOT's hardware requirements:

All loop amplifier units shall be in accordance with NEMA TS2-Section 6 and shall follow type C, 2 channel with delay and extend, as stated in NEMA TS2-6.5.2.2.1. All amplifiers shall be selected from the Department's List of Approved or Prequalified materials for each type of amplifier. In addition, loop amplifiers shall have an LCD display or a RS-232 serial data connection and software interface capable of displaying loop status including but not limited to operating frequency and $-\Delta L/L$, diagnostics, and all amplifier settings and operating parameters. Edge mounted printed circuit boards and 2310 rack cards shall not have jumper wire modifications unless the jumper wires are permanently bonded to the PCB over its entire length.

All detection components including amplifiers, racks, auxiliary BIU, interface panels, lead-ins, and all connecting harnesses shall provide one count output channel per lane of each approach within project limits. All loop amplifiers designated for counting shall meet all requirements as above and shall additionally transmit channel 1 & 2 count pulses on the edge connection assigned to channels 3 & 4 respectively. Counting amplifiers shall be configured with count outputs mapped to and recorded in the CU detector logs. The status output of each active counting channel (3 and/or 4) shall be set to logic ground by software configuration within the amplifier or externally by use of jumper card in the adjacent slot.

An auxiliary BIU panel may be used strictly for count outputs (channels 3 and/or 4 only); in this configuration, the status outputs for those count output channels may be wired to logic ground on the BIU panel. The status outputs for all standard output channels shall provide accurate status data at all times. All detector input data to the CU shall remain accurate at all times.

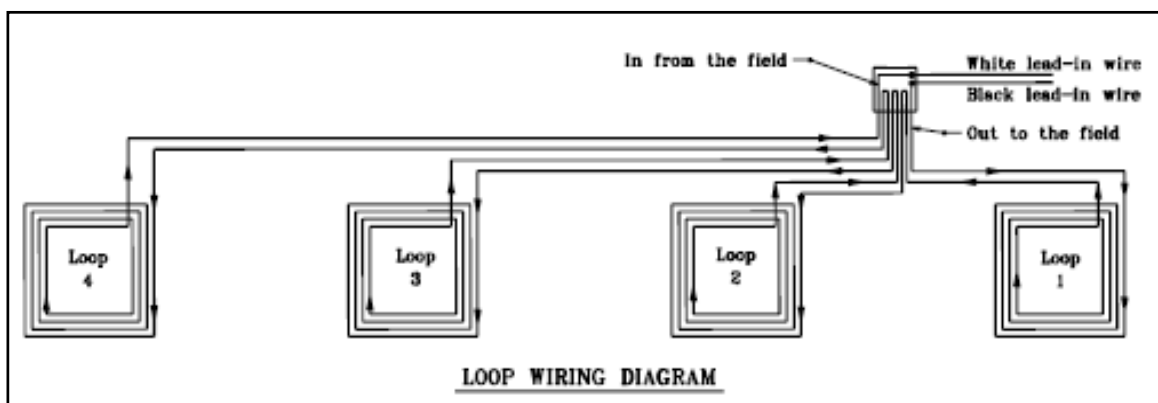

Figure 28. INDOT Loop Wiring Diagram

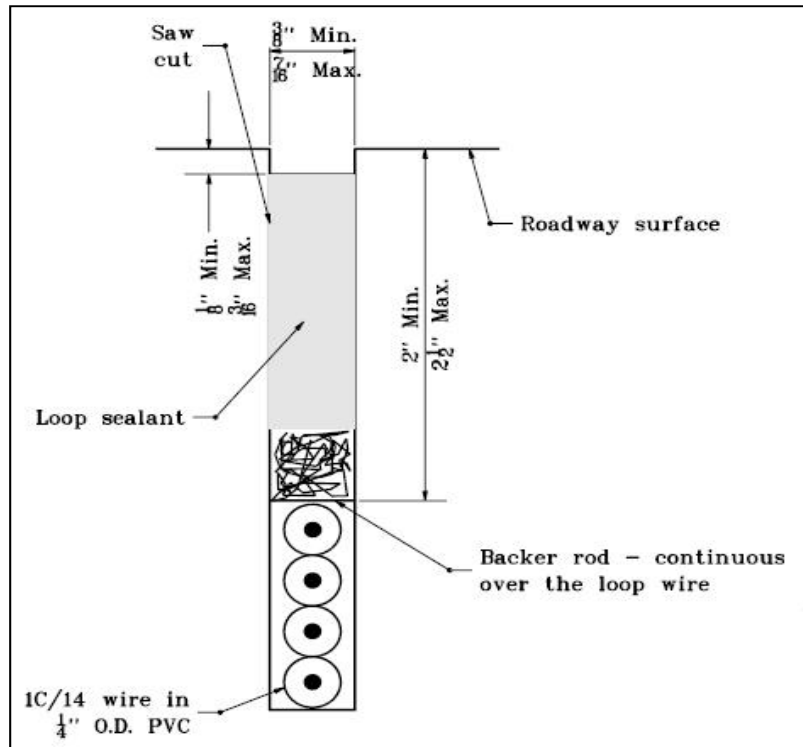

Figure 29. A Typical Loop Saw-Cut Detail

All size 5 (M) & size 6 (P-1) cabinets shall incorporate a 16 channel detector rack, configuration #2, as per NEMA TS2-5.3.4 and shall allow operation of a two channel detector in each slot and the capability of operation of a two channel counting amplifier in each even-numbered slot with the respective count outputs in each odd numbered slot. The number of detector racks provided shall be determined by the loop tagging table. All size 3 (G) cabinets shall incorporate an 8 channel detector rack, configuration #1, as per NEMA TS2-5.3.4. Figure 28 and Figure 29 show INDOT's traffic signal loop wiring diagram and a typical loop saw-cut detail, and Figure 30 and Figure 31 show INDOT's standards for detector loop installation details.

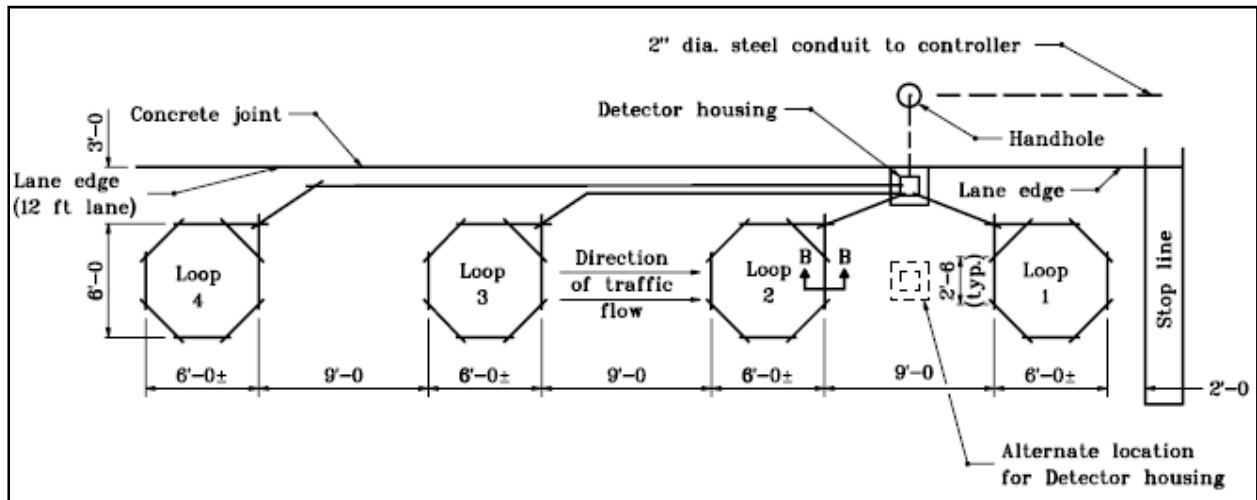

Figure 30. INDOT Typical Traffic Loop Detector Standards for One Lane

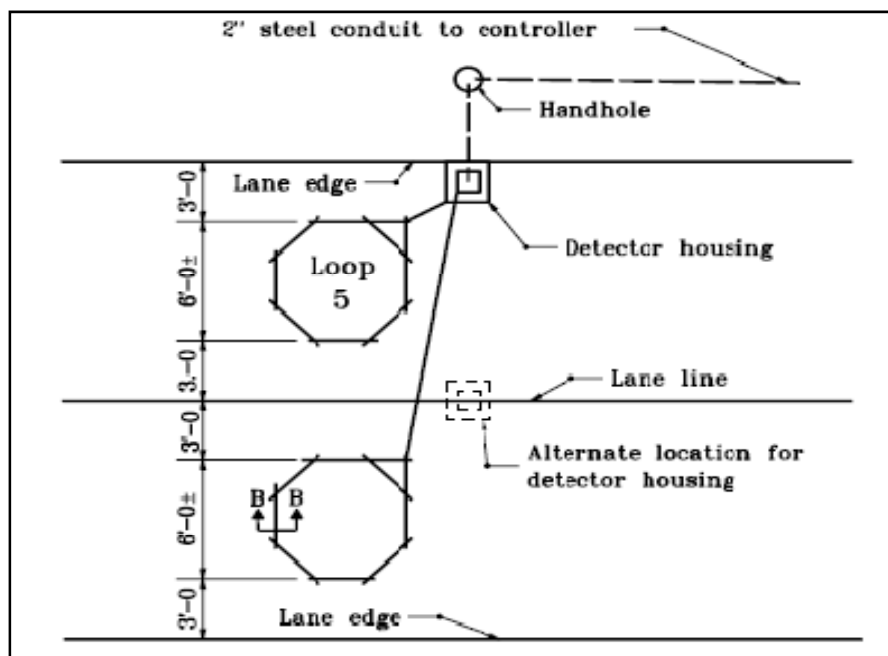

Figure 31. INDOT Typical Traffic Loop Detector Standards for Two Lanes

4.6 State of Maryland

Figure 32 and Figure 33 depict the MDOT automatic traffic recorder (ATR) loop detection standards.

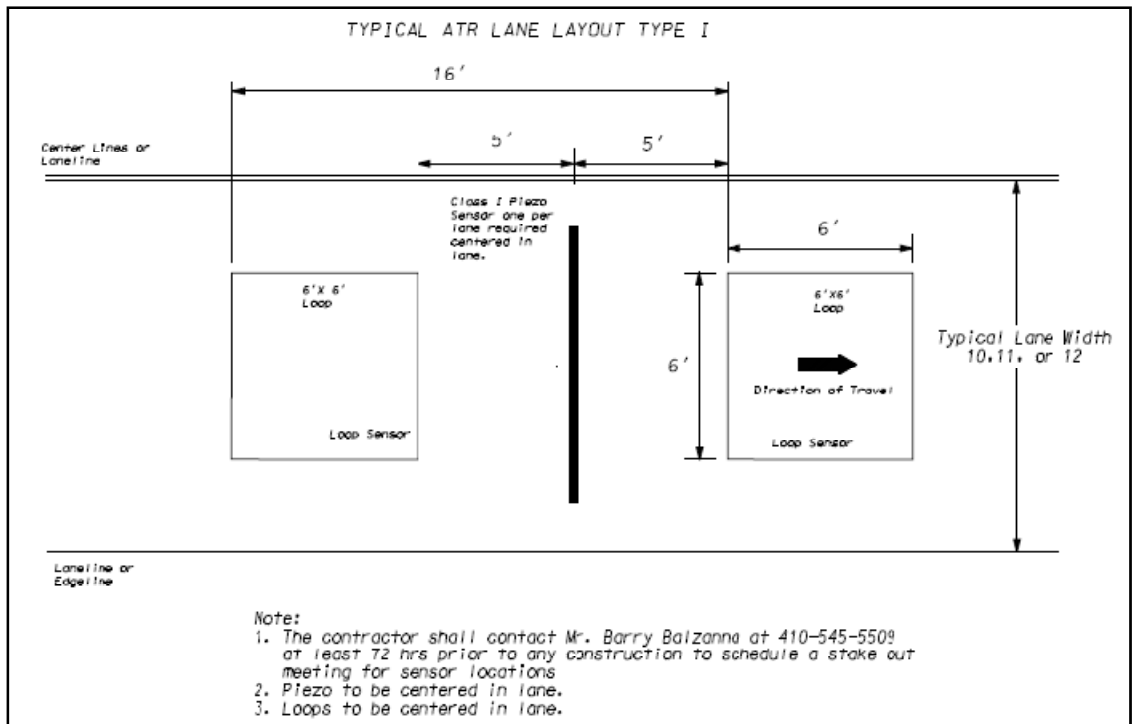

Figure 32. MDOT ATR Loop Detector Layout Standards (Type I)

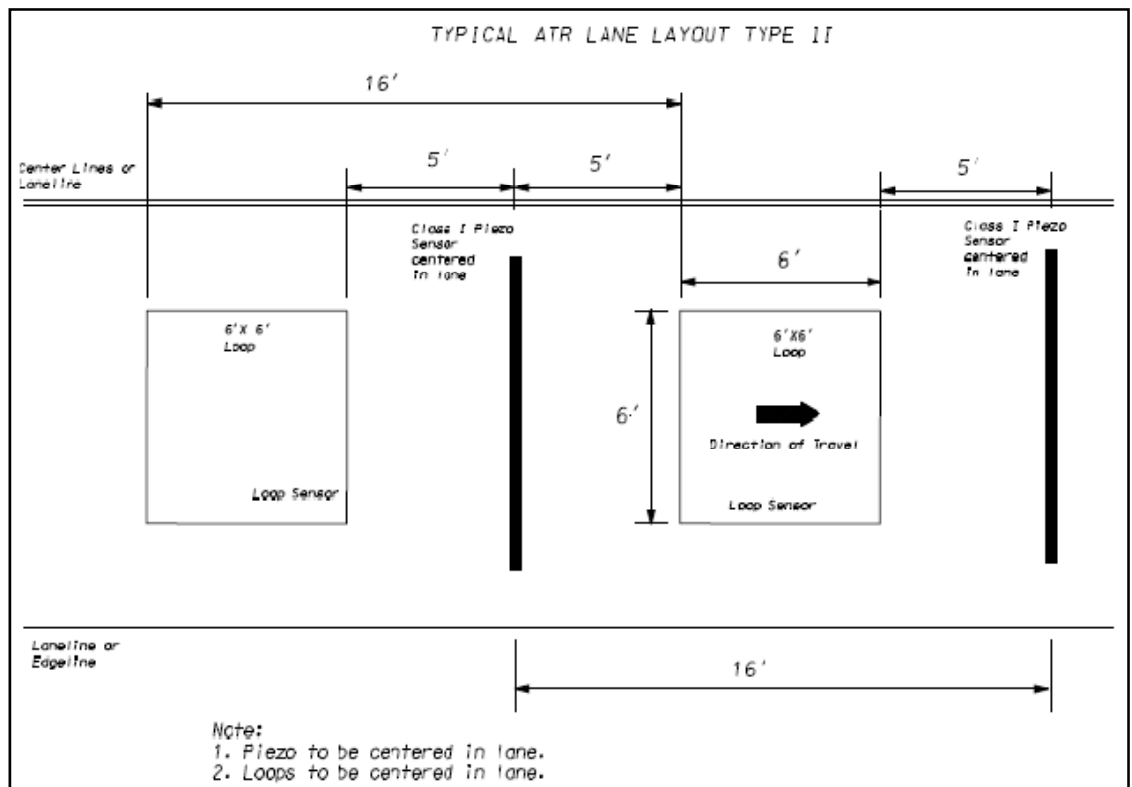

Figure 33. MDOT ATR Loop Detector Layout Standards (Type II)

4.7 State of Massachusetts

Mass Highway Department (MHD) has a well-established traffic data collection program comprising of roughly 240 continuous volume count stations that use inductive loops and counters/classifiers. They also conduct about 2500 annual short-duration counts conducted by use of traffic recorders and pneumatic tubes. The state has 9 Weigh-in-Motion (WIM) stations which utilize a combination of inductive loops and piezo-electric sensors.

The roadway wire loop detectors to be used on Massachusetts highways and streets shall conform to the following standards:

Loop Wire: Shall be single conductor, No. 12 AWG, stranded copper wire, cross-linked polyethylene insulated, rated 600 volts, type XLP-USE. The loop wire shall be encased in a 6.35-mm (1/4") OD flexible plastic tubing formed by continually extruding the tube over the wire assembly, allowing the wire to slip freely within the tubing. Loop wire shall conform to IMSA specification 51-5.

Shielded Lead-In Cable: Shall be No. 12 AWG, stranded copper twisted pair wire, 100% shield jacketed or a manufacturer's recommended lead-in cable to allow multiple independent channel operation in a single cable.

Connections: Shall be made with approved terminals or connectors applied with a crimping tool (MHD-813.60, 815.64).

Soldering: All wire loop sensor/shielded lead-in splices and connections shall be soldered using 60% tin/40% lead rosin-core electronic solder meeting the requirements of Federal Specification QQ-571D (MHD-815.64). Flame shall not be used for soldering. An electrical pencil soldering iron not exceeding 35 watts shall be used.

Splicing Insulator: Shall be heat-shrinkable, black homogeneous tubing made of thermally stabilized polyolefin to be used in conjunction with electrical insulation putty. The tubing shall have factory-applied sealant on the entire surface of the tubing. The electrical insulation putty shall be capable of sealing out moisture in multi-conductor cable connections. Splices are only allowed in pull boxes and shall conform to MHD 813.60.

Saw Cut Sealant: The loop sealant shall be a flexible embedding sealer (Bondo detector loop sealant or approved equal).

Loop Detector Installation: Roadway loop wires shall be installed after the completion of the binder course and before the installation of the wearing surface. The Engineer shall verify the proper lane markings to ensure the loops are centered in each lane. The location of each loop sensor and loop leads shall be marked on the pavement, using the typical layout shown on the plans, and approved by the Engineer before cutting the slots. A power saw of at least 26 kW (35 Hp) equipped with a diamond blade shall be used to cut a slot in the pavement. The saw can be wet or dry at the discretion of the contractor. The saw must be equipped with a depth gauge and horizontal guide to assure proper depth and alignment of the slot. The diamond blades to be

utilized for the saw cut shall provide a clean, well-defined 9.5-mm (3/8") wide saw cut without damage to adjacent areas. The saw cut depth for loops shall be 50.8-mm's (2"), or as directed by the Engineer. A 31.8-mm (1 1/4") diameter hole shall be drilled at each intersecting saw cut or lead in angle point to prevent sharp bends in the loop wire. All cuts and drilled holes shall be to the full 50.8-mm (2") depth. All saw cuts connecting the loops with the edge of pavement must be separated by at least 0.3 m (1 foot). This separation is necessary to preclude the premature breaking up of pavement.

Figure 34 shows a typical traffic data collection stations (TDCS) plan used by MHD. They use the standard 6' x 6' loop detectors.

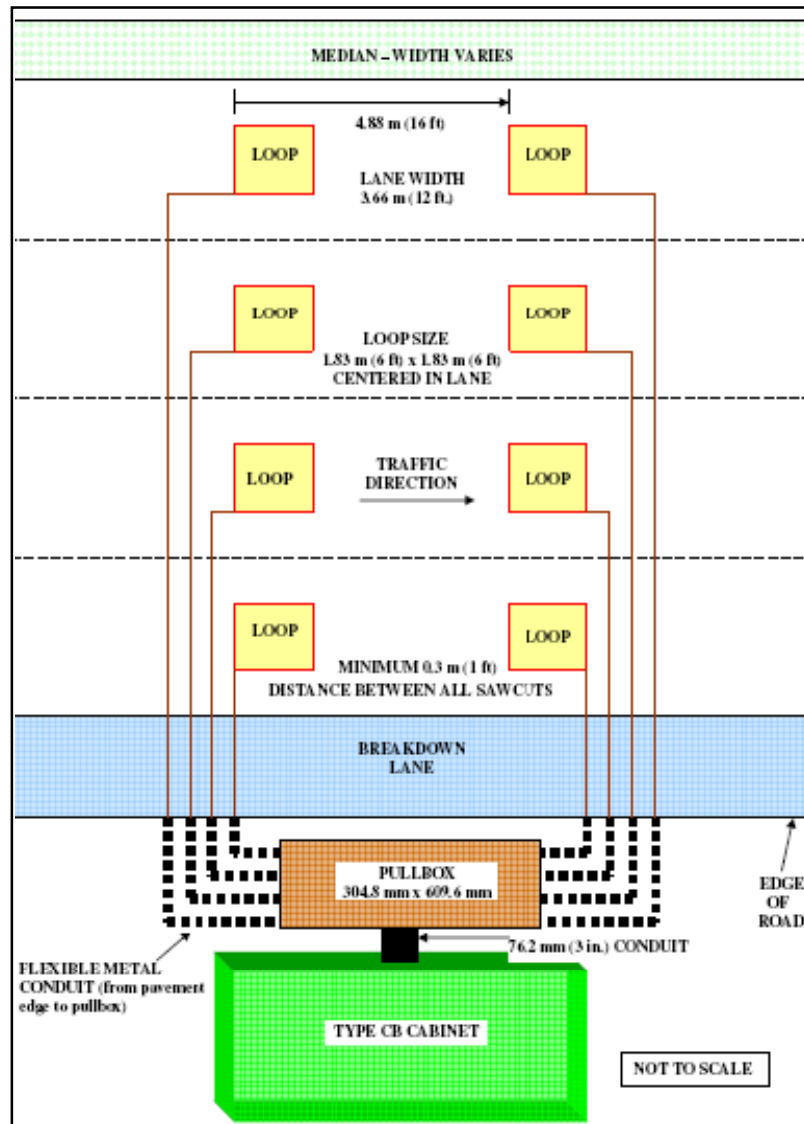

Figure 34. MHD Plan Showing Arrangements of Loop Detectors for Traffic Data Collection Stations

4.8 State of Michigan

Figure 35 shows that MDOT uses 6' x 6' and 6' x 25 to 60' loops for intersection traffic detection purposes. MDOT recommends that 3 turns are required for loops equal to or greater than 6' x 10' and 4 turns are required for loops less than 6' x 10'.

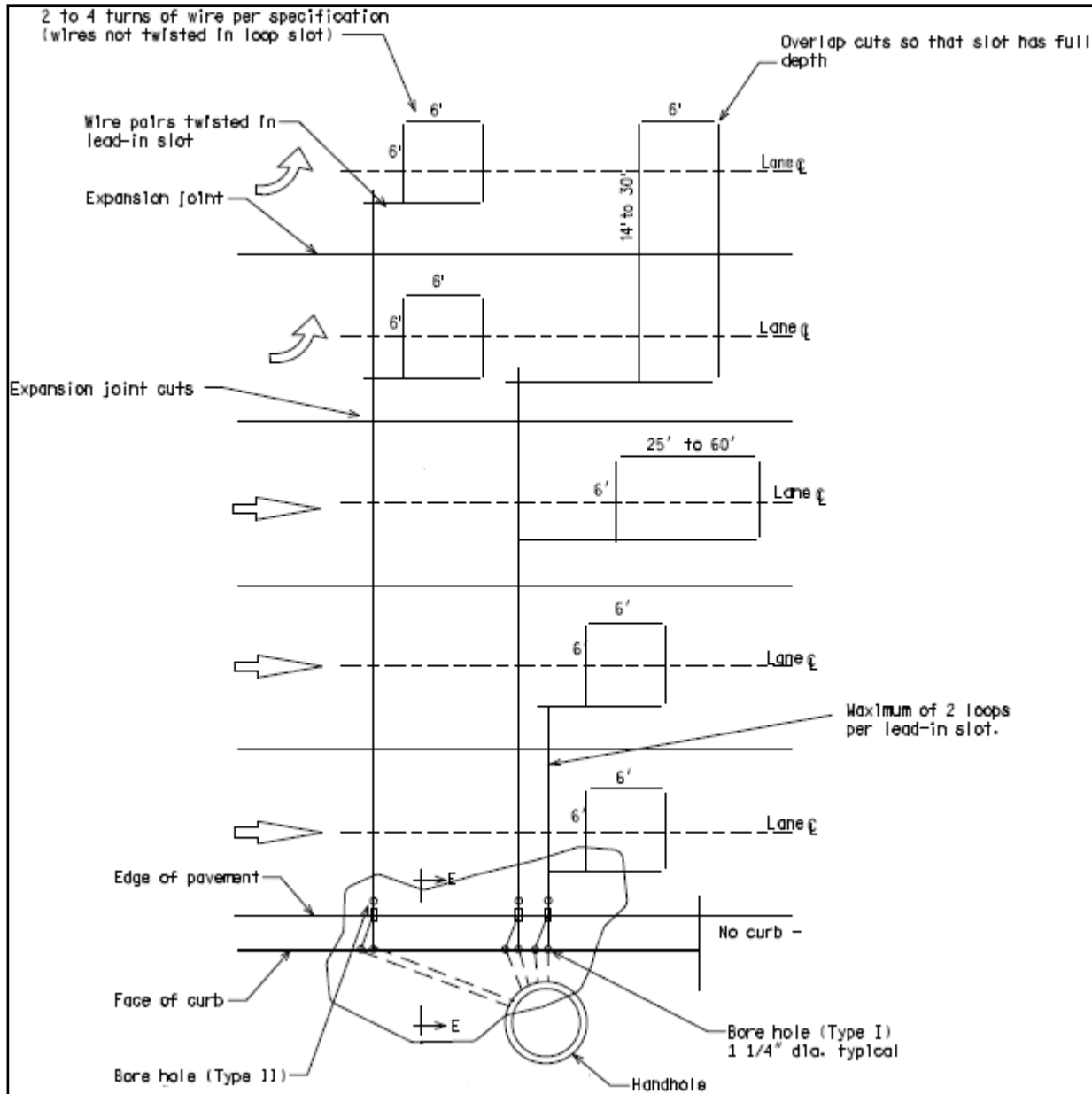

Figure 35. Typical Loop Detectors Arrangements for MDOT Signalized Intersections

4.9 State of Mississippi

As far as loop size and placement are concerned, the Mississippi Department of Transportation

(MDOT) follow ITE guidelines set forth in the Manual of Traffic Signal Design, 2nd Edition. For Presence detection, which they use on all left turn lanes and on all side streets, they use a 6' x 50' loop placed at the stop bar. For advanced detection, MDOT places a 6' x 6' loop approximately 5 seconds travel time based on 85th percentile speed in advance of the stop bar. This setback distance is also equivalent to Safe Stopping Distance. MDOT also supplied an electronic copy of a standard drawing of loop detector details for traffic signal installation sheet. Figure 36 and Figure 37. MDOT's Loop Detector Installation Details for Small Detector show Mississippi DOT's loop detector installation details.

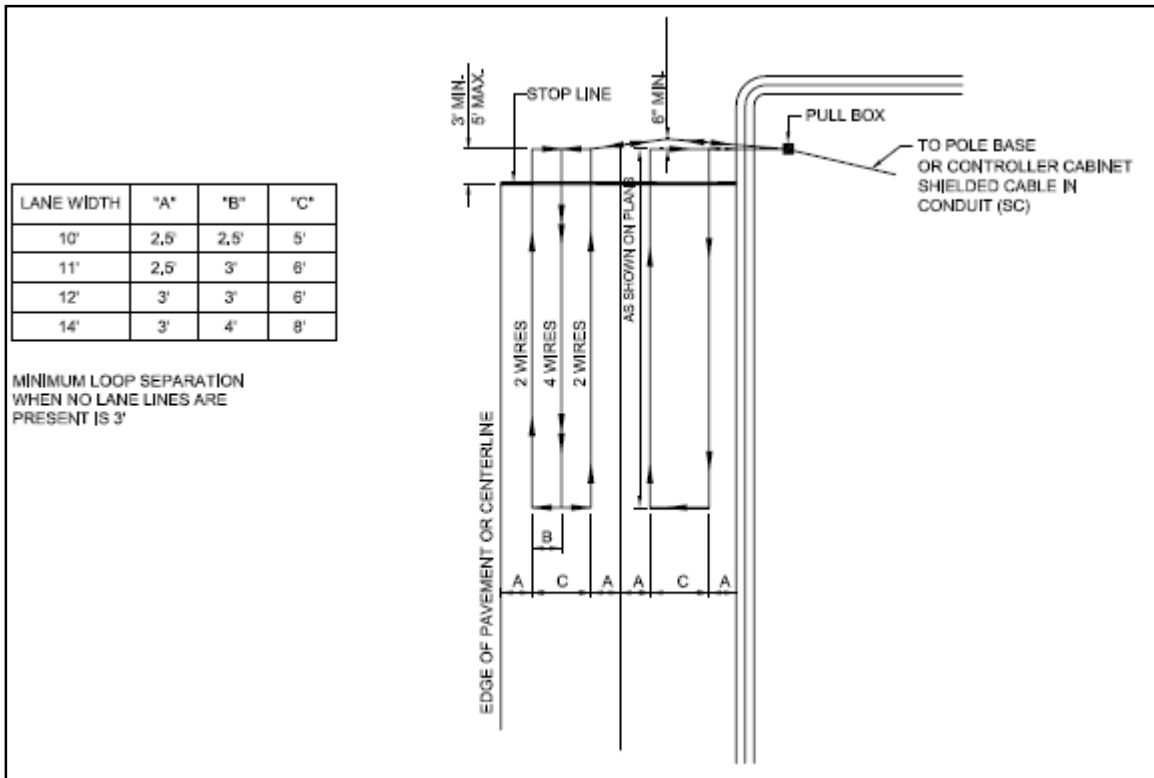

Figure 36. MDOT's Loop Detector Installation Details for Large Detector

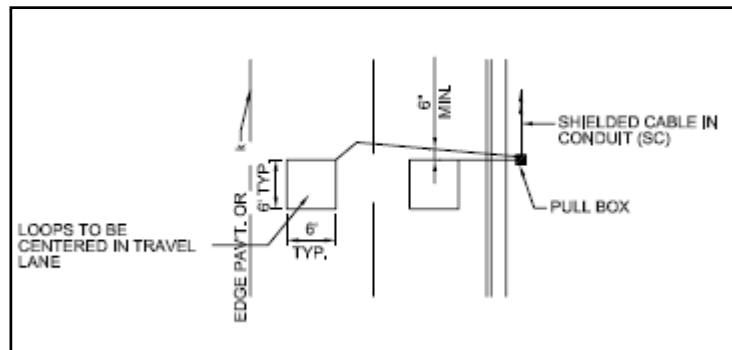

Figure 37. MDOT's Loop Detector Installation Details for Small Detector

4.10 State of Montana

The typically used loops in the Montana Department of Transportation (MDT) have a 6ft × 6ft square shape with the distance of 16ft between each other.

4.11 State of New Jersey

New Jersey Department of Transportation (NJDOT) no longer use loop detectors for traffic signal vehicle detection. However, they use traffic monitoring loops for ITS application. Typical loop detector installation and loop configurations used in the state of New Jersey are shown in Figure 38 and **Error! Reference source not found.**

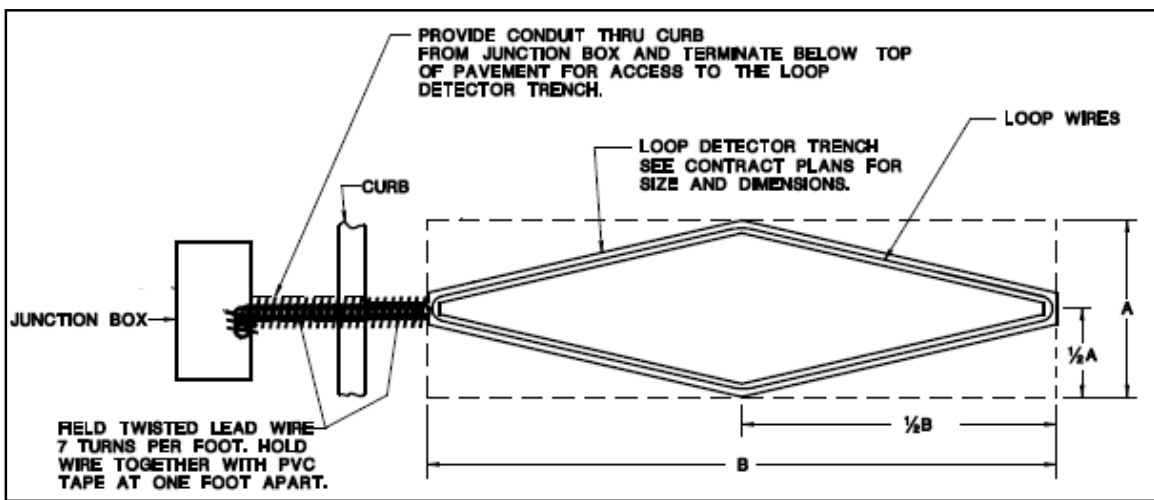

Figure 38. NJDOT's Typical Loop Detector Installation

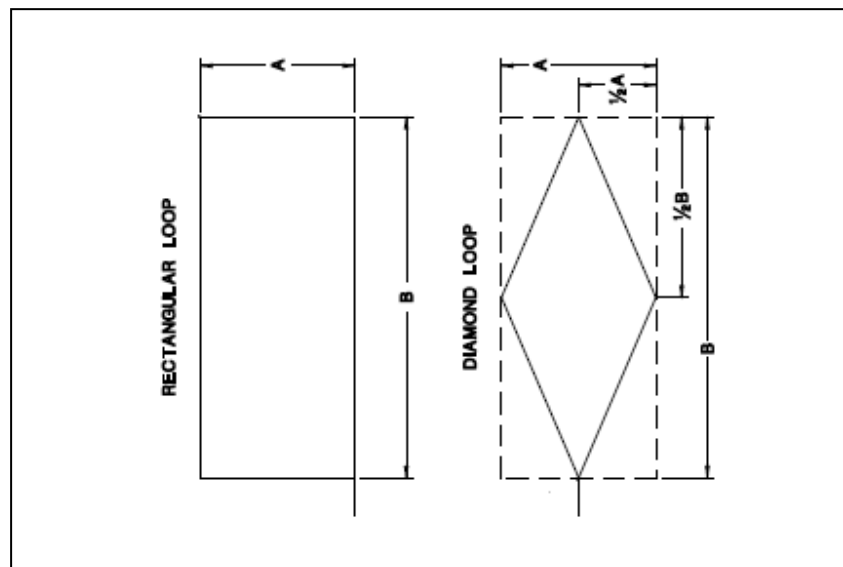

Figure 39. NJDOT's Loop Configurations

4.12 State of New York

New York State DOT (NYSDOT) believes that one advantage of the inductive loop detectors is the wide range of permissible loop geometries. The size and number of turns of the loop wire or combination of loops, together with the length of lead-in wire, must produce an inductance within a range compatible with the design of the detector amplifier and the system requirements. If the inductance falls outside of the required range, the detector will not operate properly. NYSDOT Models 222/224 loop detector modules are designed to operate within an inductance range of 50 microhenries (μh) to 2000 μh . Loop layout and size should be determined by the detection requirements of the intersection approach and the capabilities of available equipment.

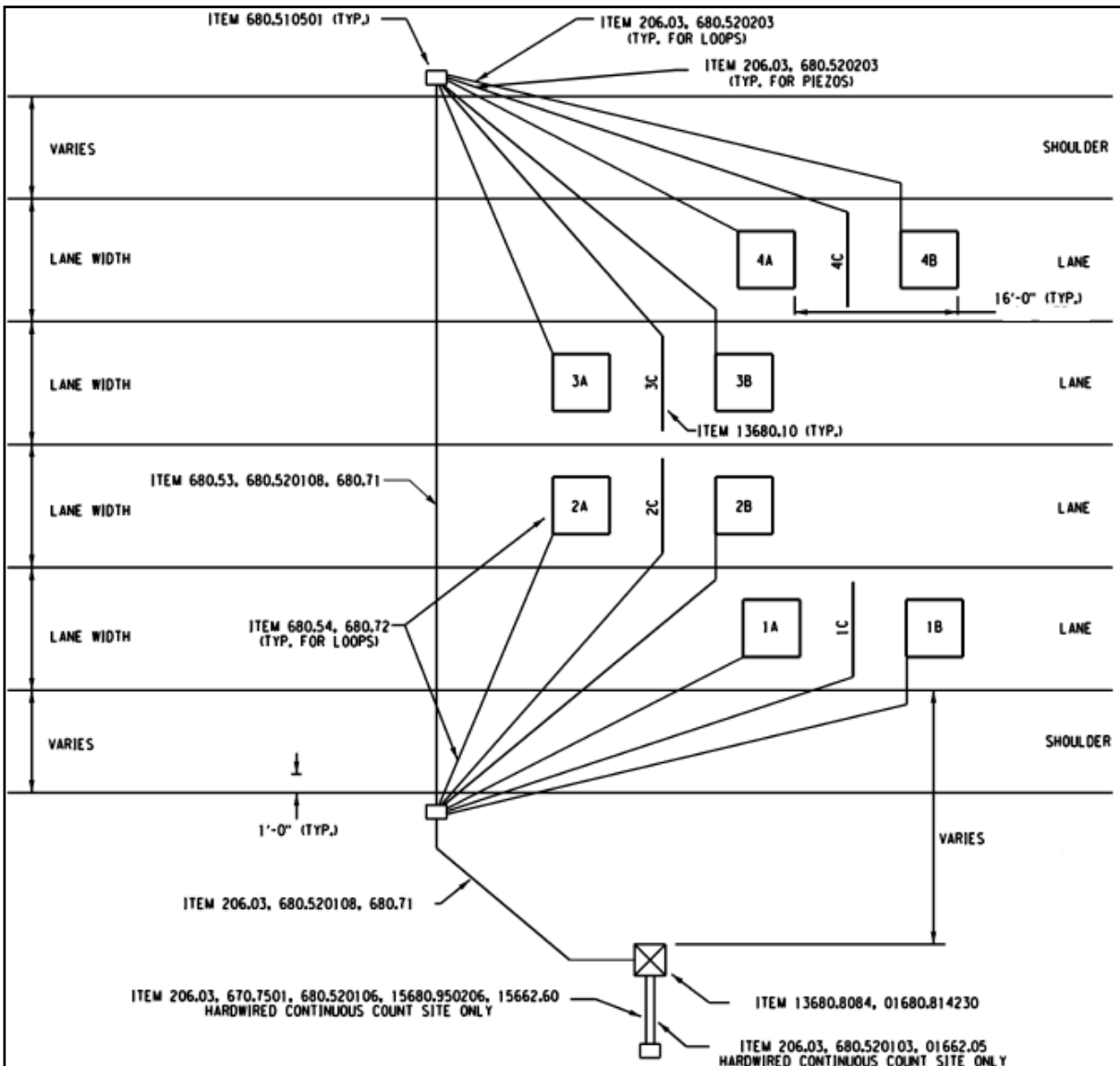

Figure 40. Loop Detector Arrangements at a Typical 4-Lane Count Station in NY

Loop Configuration: The magnetic field emanating from the loop wire extends from 0.9 m to 1.2 m on each side of the loop wire. The width of the loop should be 1.8 m to ensure that there are no dead spots and that an adequate detection area is provided. To be detected, a vehicle must cross over, or occupy, at least 15% of the loop perimeter being accommodated by a single detector channel. The length of the loop and the number of turns is governed by the inductance of the loop system and the tuning range of the detector amplifier, as well as the detection requirements of the approach.

Inductance: A prime design consideration is the verification that the total inductance of the loop and lead-in system connected to one detector channel will operate within the tuning range of available loop detector amplifiers. NYSDOT Model 222 and 224 loop vehicle detector modules are designed to operate correctly when connected to an inductance of from 50 μ h to 2000 μ h.

In designing a loop and lead-in system, the total inductance should be kept between 60 μ h and 1600 μ h. This provides for a 20% safety factor with equipment currently in use. Avoid more than 225 m of lead-in cable per channel. If more than 300 m of lead-in is required, install a detector cabinet and detector amplifier between the detector and the controller cabinet. **Error! Reference source not found.** show an example of loop detector arrangements at a typical 4-lane permanent short count station.

4.13 State of Oregon

Table 10 shows the recommendations of the Oregon Department of Transportation (ODOT) on loop detector spacing based on posted speed limits.

Table 10. ODOT’s Recommended Loop Spacing

LOCATION	SPEED		LOOP SPACING (referenced from the stop line to center of loop)
	mph	Ft/sec	feet
Main Line	25	36.75	140
	30	44.10	180
	35	51.45	110/220
	40	58.80	160/320
	45	66.15	160/320
	50	73.50	190/380
	55	80.85	225/450
Right Turn Lane			140 (or 115 if short lane)
Side Street/ Left Turn			5/15/75
Interchange Ramps			5/15/75/135
Bikes--Main Line	15	22.05	50
Bikes--Side Street	10	14.70	4/50

LOCATION	SPEED		LOOP SPACING (referenced from the stop line to center of loop)
Main Line--Temporary Bridge**			5/15/100 65**
Speed X 1.47= feet/second			
**A bypass loop may need to be installed in opposing lane 65' from the stop bar.			

4.14 State of Pennsylvania

Pennsylvania Department of Transportation (PennDOT) uses vehicle detection systems that are generally comprised of three components: (a) the detector amplifier, (b) lead-in cable, and (c) a unit in the roadway surface or overhead. The two modes of operation for detectors used are:

- *Pulse mode:* when the mode selection switch is in the PULSE position, the detector provides one output pulse having a pulse width of 75 milliseconds to 150 milliseconds for each vehicle passing or stopping in a detection area. The pulse mode provides a locking call on the controller until serviced. Since long detection areas are of little advantage when pulse detection is used, pulse detection is typically associated with the less expensive short detection areas.
- *Presence mode:* when the mode selection switch is in the PRESENCE position, the detector provides one output pulse for each vehicle passing over the detection area, or an output for a minimum of 180 seconds for a vehicle stopped over the detection area. Presence detection is typically associated with long, stop line detection areas and non-locking operation.

Three basic configurations of loops utilized by PennDOT are as described below:

Short Loops. Short loops may operate in either the pulse mode or the presence mode. The short loop may be installed either alone, or in conjunction with other short loops to create a large detection area. Sizing and layout criteria are as follows:

- The length shall be 1.8 m (6 ft).
- The minimum width shall be 1.5 m (5 ft).
- The sides of the loop should be 0.9 m (3 ft) from either edge of the travel lane.
- For single loops, the location from the stop line is determined by the speed of approaching vehicles.
- For sequential short loops, the detection area shall be comprised of four loops and shall be approximately 21 m (70 ft) long. The first loop shall be placed so that it extends 0.9 m (3 ft) beyond the stop line. The second, third, and fourth loops shall be sequentially spaced at 3 m (10 ft), 4.5 m (15 ft) and 6 m (20 ft), respectively.

Long Loops. Long loops shall operate in the presence mode only. The long loop is used to provide a large detection area with one loop. Each lane of a detectorized approach shall have a separate loop. Sizing and layout criteria are as follows:

- The maximum length shall be 15 m (50 ft).
- The maximum width shall be 2.4 m (8 ft) and the minimum 1.5 m (5 ft).
- The sides of the loop should be 0.9 m (3 ft) from either edge of the travel lane.
- The front edge of the loop may extend 0.9 m (3 ft) beyond the stop line.

Modified Long Loops. The modified long loop was devised to address the problem of adjacent lane detection in very high sensitivity inductive loop systems. The outer configuration of the loop is identical to conventional loops, but has a saw cut down the center. The loop consists of wire laid in a figure 8 pattern in the saw cut, thus creating two narrow loops laid side-by-side. This winding pattern creates fields that cancel outside the perimeter of the loop and are enhanced within it. Modified long loops are more effective than conventional loops in the detection of small vehicles such as bicycles and small motorcycles. The procedures for sizing and layout shall be identical to those for both short and long conventional loops. Examples of typical loop detector standards used by PennDOT are shown in Figure 41. Figure 42 shows an example of an example of loop detector that enhances bicycle and motorcycle detection.

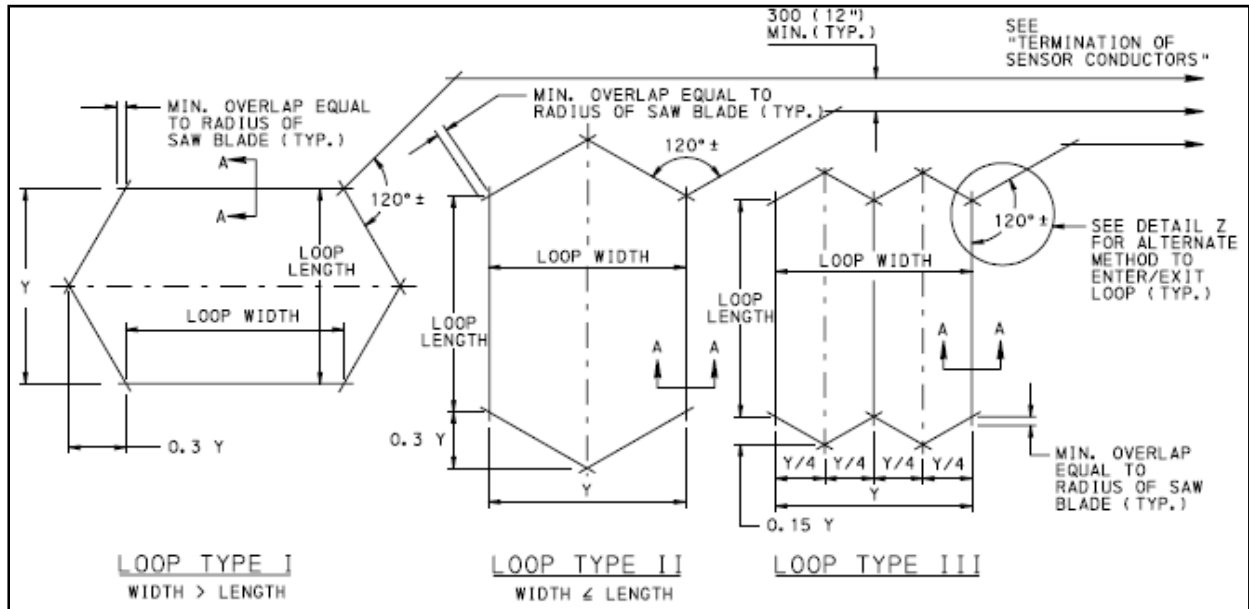

Figure 41. Typical Loop Detectors used by PennDOT

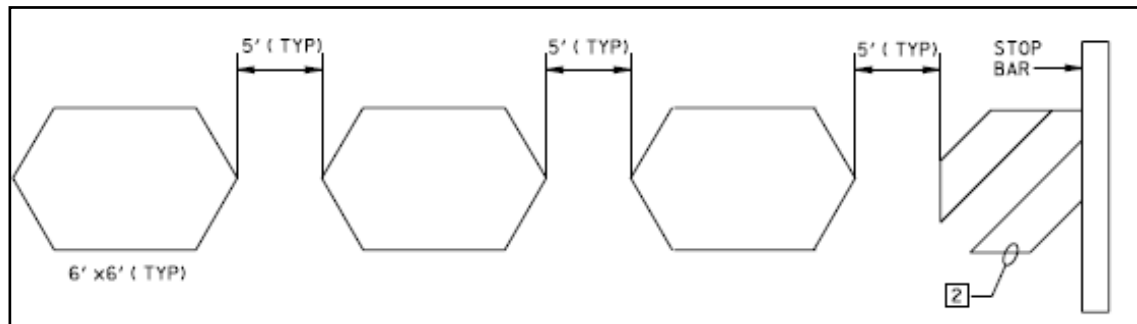

Figure 42. A Typical Loop Detector for An Enhanced Bicycle and Motorcycle Detection

4.15 State of Texas

Figure 43 and Figure 44 show typical loop detector configurations used in Texas. Figure 45 depicts a typical loop saw cut section according to the Texas Department of Transportation (TxDOT) standards and Figure 46 shows typical detector loops placement details.

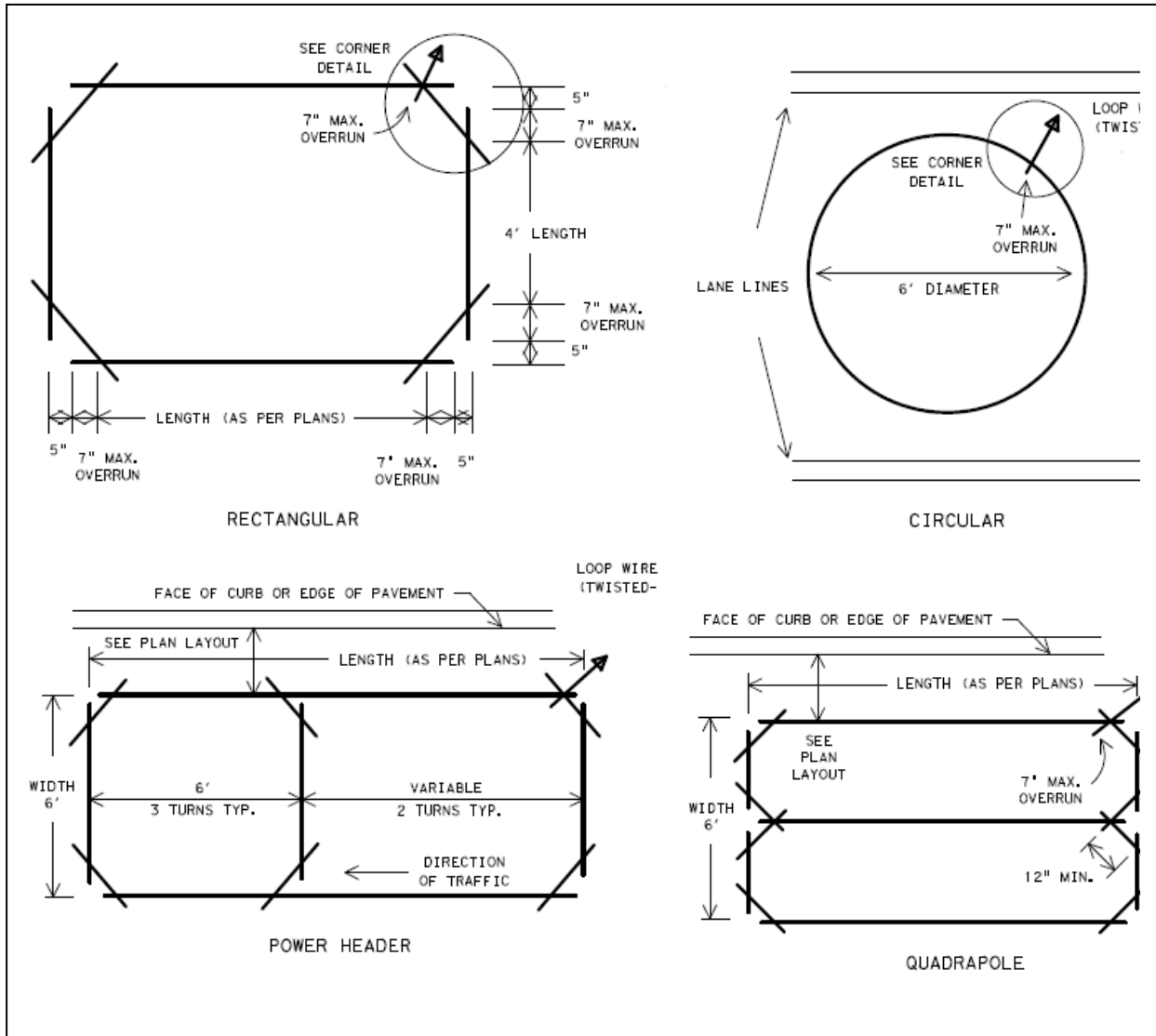

Figure 43. Typical Loop Detector Layouts Used in Texas

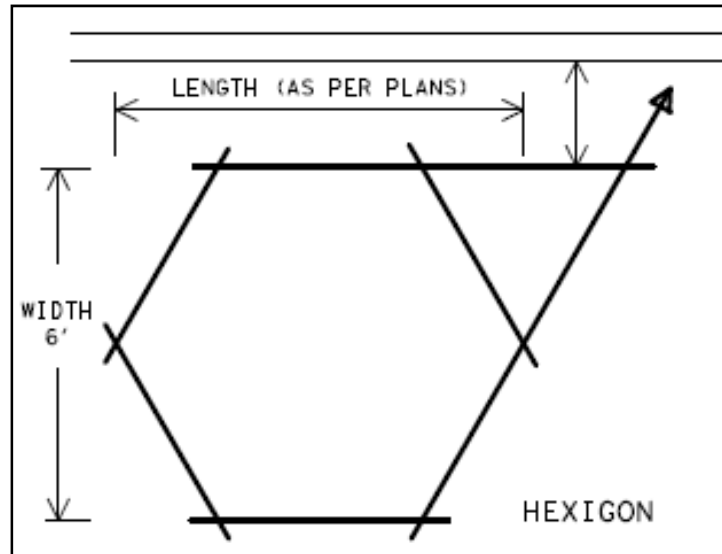

Figure 44. Typical Loop Detector Layouts Used in Texas

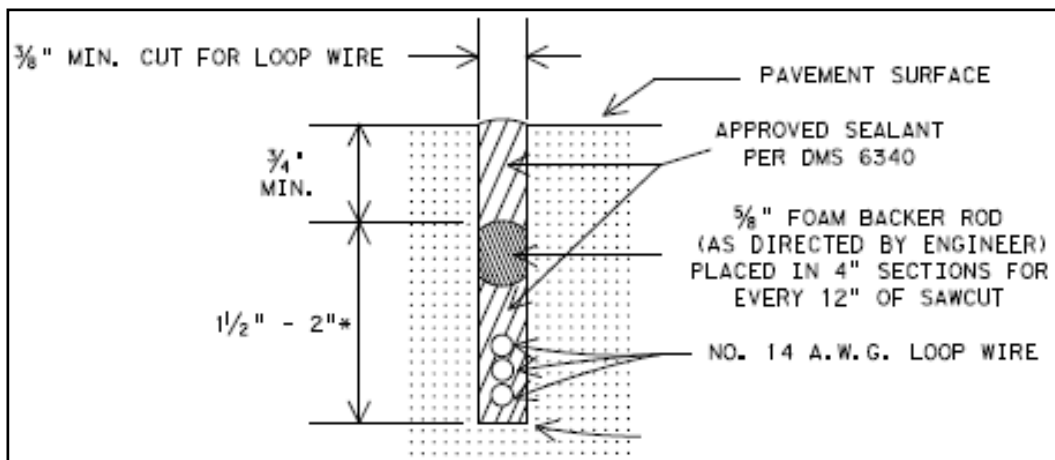

Figure 45. A Typical Loop Saw Cut Cross-Section per Texas Standards

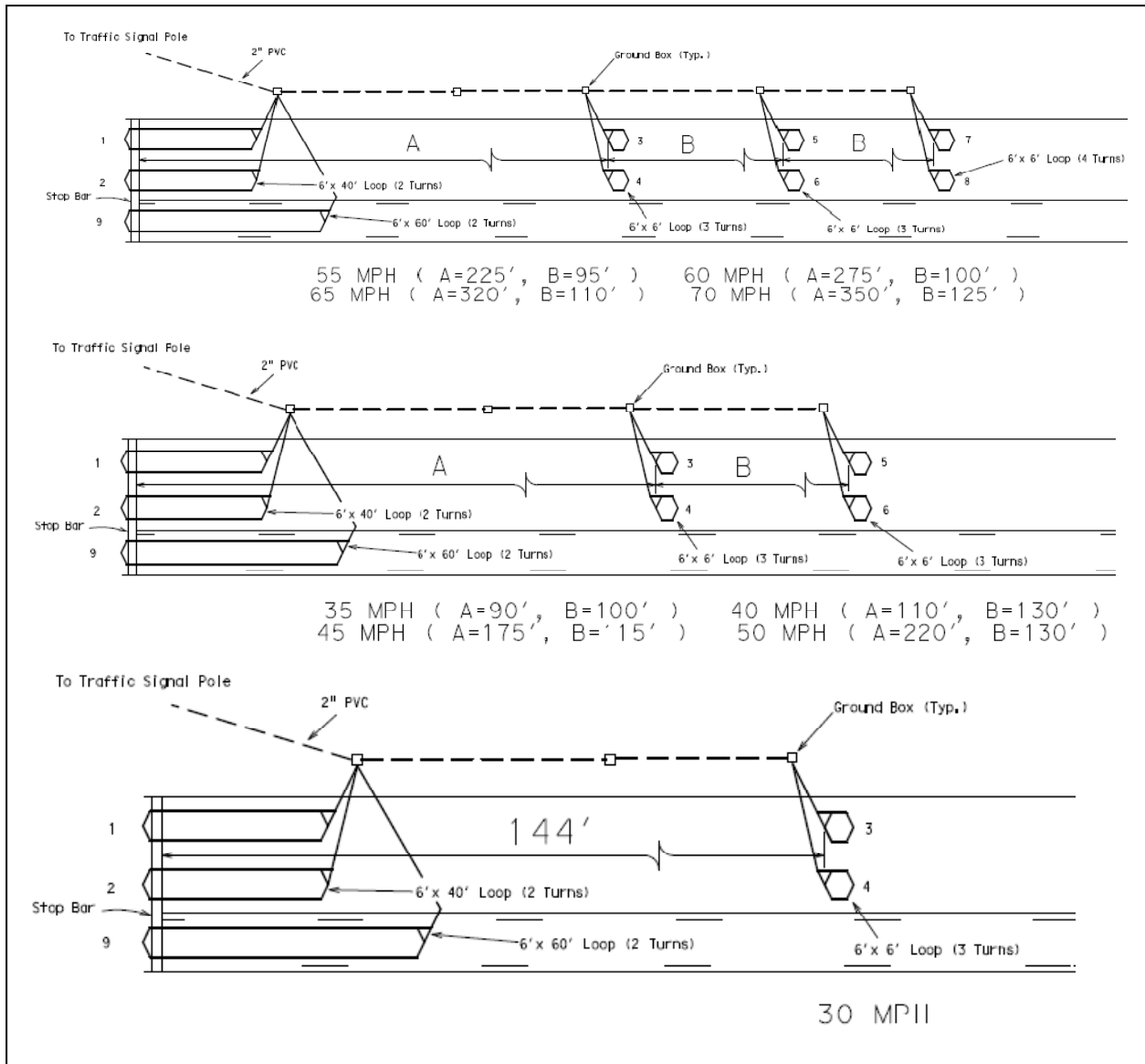

Figure 46. Texas Standards for Loop Detector Placement Details

4.16 State of Utah

Typically, the Utah Department of Transportation (UDOT) uses the 6ft x 6ft square loops and 6ft diameter circular loops as shown by Figure 47.

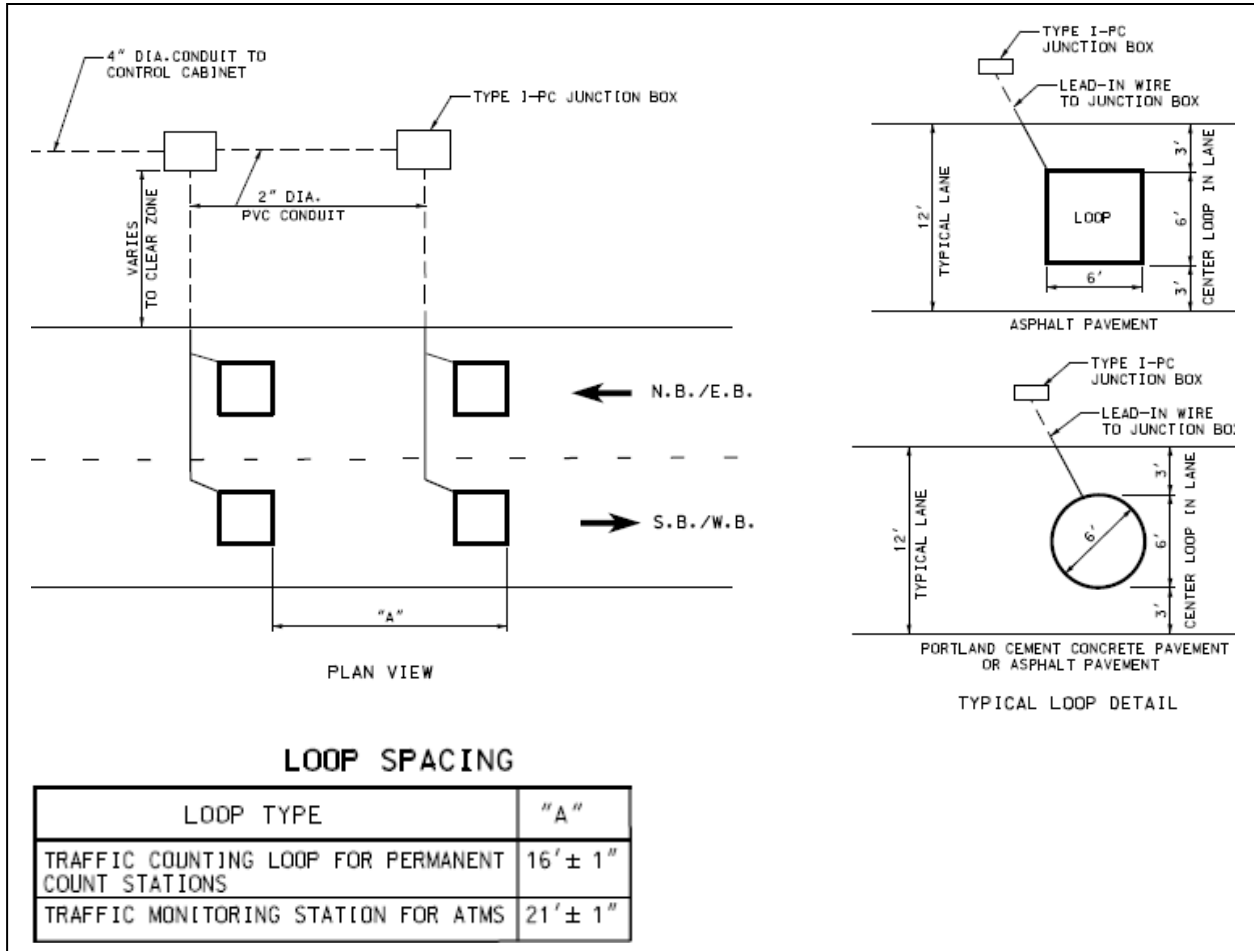

Figure 47. Typical Loop Detectors Used in Utah Highways

4.17 State of Washington

The Washington Department of Transportation (WSDOT) uses both square and circular loops for traffic detection purposes as shown in Figure 48.

Based on the detailed information provided by 17 states, it can be concluded that there are no substantial differences in their standards despite some states being more detailed than others. The most commonly used loop detectors are 6' x 6' square and 6' x 50' rectangular loops. A few states also use 6' circular loops. The smallest loop size found is a 5' x 5' square loop. The NEMA inductive loop detectors and ITE's Manual of Traffic Signal Design standards are mostly used as guides.

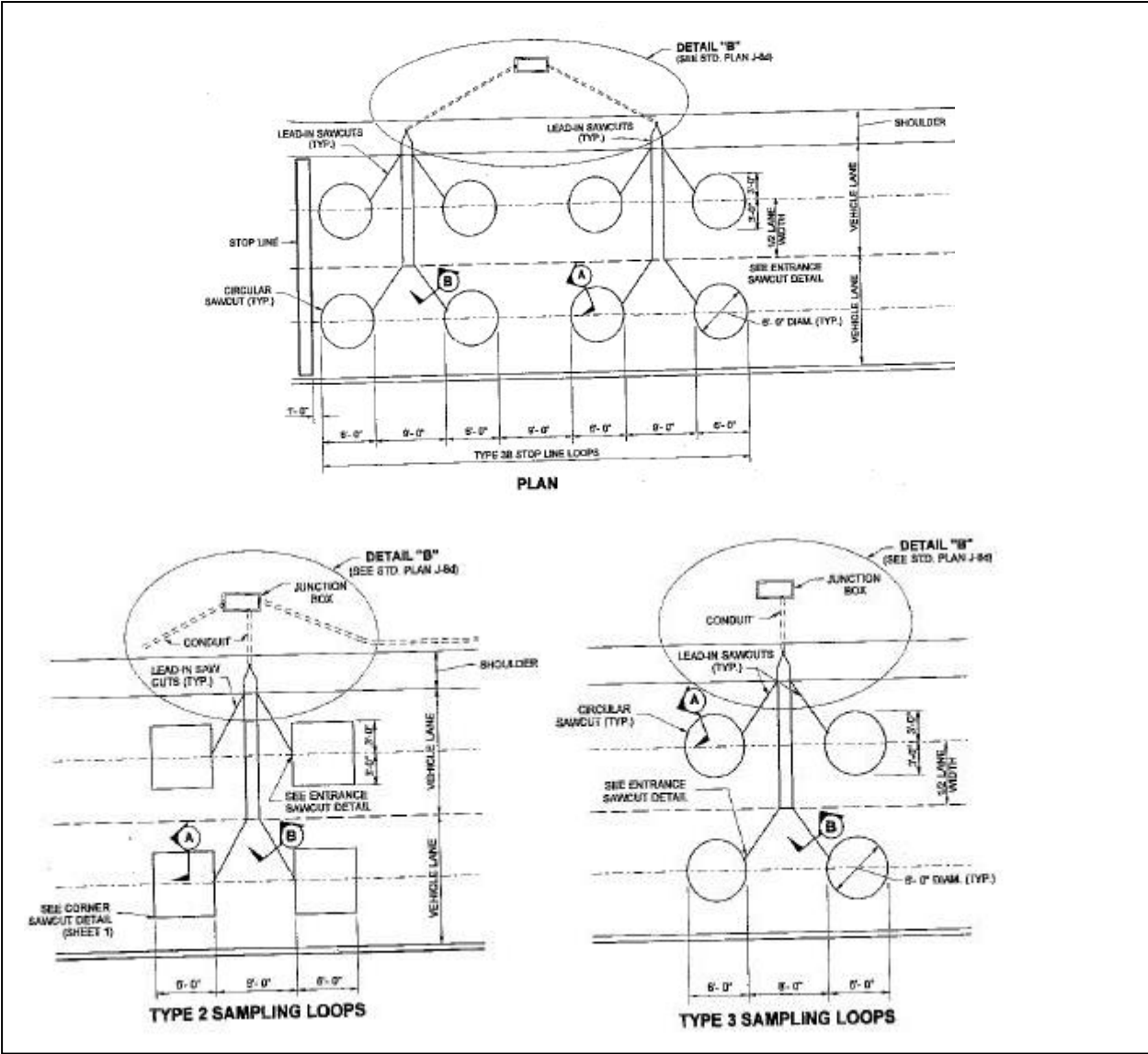

Figure 48. Typical Loop Detectors Used by Washington DOT

CHAPTER 5: TRAVEL TIME ESTIMATE BY LOOP DATA

Dual loop detectors are also used to calculate the travel time (time taken to travel between two points of interest). There are three main categories of calculating travel time, which are classified as, extrapolation methods, statistical methods and methods based on traffic flow theory (Vanajakshi, 2004).

5.1 Extrapolation Methods

Extrapolation methods are considered as the simplest and widely used methods for calculating travel time using dual loop detectors (Travel Time Data Collection Handbook, 1998). Speed is assumed to be constant for the small distance in which the travel time is calculated. The distance is usually considered to be the distance between the two loops (0.5 miles). There are three approaches in this method by which travel time is calculated.

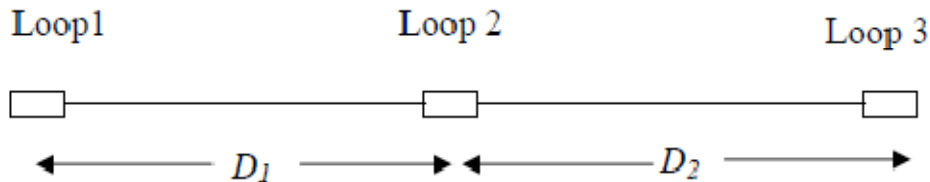

Figure 49. Figure illustrating the Extrapolation Methods

5.1.1 Half-Distance Approach

This method assumes that the speed is applicable to either side of a detector and hence the travel time is calculated as

$$T_{1-2} = \frac{1}{2} \left(\frac{D_1}{v_1} + \frac{D_2}{v_2} \right) \quad (13)$$

Where, v_1 and v_2 are the average speeds at detector 1 and 2 respectively for that particular time interval. And T_{1-2} is the travel time between loop detectors 1 and 2

5.1.2 Average Speed Approach

In this method, the travel time is calculated using the average of the average speeds measured by loops 1 and 2 and it is given by

$$T_{1-2} = \left(\frac{D_1}{(v_1 + v_2) / 2} \right) \quad (14)$$

5.1.3 Minimum Speed Approach:

Travel time in this method, is calculated using the minimum of the average speeds measured at loop 1 and loop 2 which is given by

$$T_{1-2} = \left(\frac{D_1}{v_{\min}} \right) \quad (15)$$

Where, v_{\min} is the minimum value of average speeds at loop 1 and 2.

The drawback of this method is that it cannot be applied for all the traffic flow conditions. There may be errors in the results during peak periods when traffic is congested. The assumption that speed is constant may not be justified for high volume conditions.

5.2 Statistical Methods

Many statistical methods like cross-correlation techniques, linear input-output auto regressive moving average (ARMA) model, the Kalman filtering technique, fuzzy logic and neural networks, Artificial Neural Network (ANN) analysis, signature matching techniques etc., were proposed to measure travel time using loop detectors.

5.3 Theoretical Methods

These methods include the measurement of travel time using the traffic flow theory, Kalman filtering technique (by classifying the vehicles), linear approximation of flow-density relationship etc. Travel time can also be calculated by determining the area between the cumulative volume curves obtained from loop detectors.

CHAPTER 6: CONCLUSIONS AND RECOMMENDATIONS

In this study, the existing and new developed length-based vehicle classification models have been evaluated with the ground-truth vehicle trajectory data extracted from video. Different traffic conditions, namely free flow, synchronized flow, and stop-and-go flow, have been investigated and then considered as the traffic states into the evaluation of the vehicle classification models. It has been proved that the existing vehicle classification model works well against free flow. However, traffic influencing factors have to be incorporated into the models under synchronized or stop-and-go traffic conditions, which are not in existence yet and need new development. In details, the traffic factors are considered as follows:

- 1) Relative stable accelerations or decelerations are observed for individual vehicles within the synchronized traffic, it is hence assumed that a constant acceleration or deceleration rate for each vehicle is estimated by the loop data and then adopted into the VC-Sync model; and
- 2) Eight scenarios are defined depending on the vehicle's stopping locations within the detection area as the stop-and-go traffic occurs, and the VC-Stog model is developed based on those assumed scenarios.

New length-based vehicle classification models, i.e., VC-Sync model and VC-Stog model are developed for cases of synchronized traffic flow and stop-and-go traffic, respectively. The evaluation results indicate that the VC-Sync model and VC-Stog model significantly improve the accuracy of the vehicle classification against synchronized and stop-and-go traffic flows. Comparing to the ground-truth data, the error of the estimated length by the VC-Sync model is reduced to 8.5% compared to 35.2% produced by the existing model, and the error of the VC-Stog model is reduced to 27.7% compared to 210% generated by the existing model.

In this study, it has also proven that the VEVID-based approach is efficient and cost effective to extracting the ground-truth vehicle event trajectory data. It would be difficult or even impossible to conduct this research without use of VEVID. The innovation of the proposed VEVID-based approach has been fully exhibited throughout this project.

The collected loop detector standards provide with a general overview of application of the loop detectors in many states, including detector size, shape, the installation methods, and so forth. This information can enable the study of the best installation practices for providing high quality traffic counts under various traffic conditions, as well as practical problems in applying these detectors. Methods for estimating travel time by the dual-loop data are briefly summarized, and they may be informative to the future research in generating loop-based travel information.

More samples are needed for the future research, especially for the cases under stop-and-go traffic condition. Despite a total of 26 hours of traffic video data, the sampling size for stop-and-go traffic (especially for Scenarios 5 through 8) is likely insufficient for statistical analysis, though the results from the available samples appear exciting.

REFERENCES

- Athol, P. (1965). "Interdependence of Certain Operational Characteristics within a Moving Traffic Stream." *Highway Research Record* 72, pp. 58-87.
- Ban, X., Chu, L., Herring, R., and Margulici, J.D. (2008). "Optimal Sensor Placement for Both Traffic Control and Traveler Information Applications," Compendium of Papers CD-ROM of 88th Transportation Research Annual Meeting, Washington, DC, Jan. 11-15, 2009.
- Cheeverunothai, P., and Wang, Y. (2006). "Identification and Correction of Dual-Loop Sensitivity Problems." Compendium of Papers CD-ROM, 85th Transportation Research Board Annual Meeting, Washington, DC, January 2006.
- Cheeverunothai, P., Wang, Y., and Nihan, L. N. (2005). "Development of Advanced Loop Event Analyzer (ALEDA) for Investigations of Dual-Loop Detector Malfunctions", Presented at *The 12 world Congress on Intelligent Transportation Systems*, San Francisco.
- Chen, L., and May, A. (1987). "Traffic detector errors and diagnostics", In *Transportation Research Record: Journal of the Transportation Research Board*, No. 1132, TRB, National Research Council, Washington, D.C., pp. 82-93.
- Coifman, B. (1999). "Using Dual Loop Speed Traps to Identify Detector Errors," Compendium of Papers CD-ROM, 78th Transportation Research Board Annual Meeting, Washington, DC, January 10-13, 1999.
- Coifman, B. (2004a). *Research Reports: An Assessment of Loop Detector and RTMS Performance*. Report No.: UCB-ITS-PRR-2004-30. ISSN 1055-1425.
- Coifman, B., and Dhoorjaty, S. (2004b), "Event Data Based Traffic Detector Validation tests", *Journal of Transportation Engineering*, Vol.130, No.3.
- Coifman, B., and Kim, S. B. (2008). "Speed Estimation and Length Based Vehicle Classification from Freeway Single Loop Detectors." *Compendium of Papers CD-ROM for the 87th Transportation Research Board Annual Meeting*, Washington, DC, Jan. 13-17, 2008.
- Eddie, L.C. (1961). "Car following and steady-state theory for non-congested traffic." *Operations Research* 9, pp. 66-76.
- Fei, X., Mahmassani, H. S. (2008). "A Two-Stage Stochastic Model for the Sensor Location Problem in a Large-Scale Network." Compendium of Papers CD-ROM, 87th Transportation Research Board Annual Meeting, Washington, DC, January 13-17, 2008.
- Fujito, I., Margiotta, R., Huang, W., and Perez, W. A. (2006). "The Effect of Sensor Spacing on Performance Measure Calculations." Compendium of Papers CD-ROM, 85th Transportation Research Board Annual Meeting, Washington, DC, January 15-19, 2006.
- Elefteriadou, L., and Lertworawanich, P. (2003). "Defining, Measuring and Estimating Freeway

- Capacity.” Compendium of Papers CD-ROM, 82nd Transportation Research Board Annual Meeting, Washington, DC, January 2003.
- Habib-Mattar, C., Polus, A., and Cohen, M. A. (2009). “Analysis of the Breakdown Process on Congested Freeways.” Compendium of Papers CD-ROM, 88th Transportation Research Board Annual Meeting, Washington, DC, January 2009.
- Helbing, D., Hennecke, A., and Treiber, M. (1999). “Phase Diagram of Traffic States in the Presence of Inhomogeneities.” *Physical Review Letters*, Volume 82, Number 21, May 1999. Hall, F.L. and Gunter, M.A. (1986). “Further analysis of the flow-concentration relationship.” *Transportation Research Record: Journal of the Transportation Research Board*, No. 1091, TRB, National Research Council, Washington, D.C., pp. 1-9.
- Kwon, J., Petty, K., and Varaiya, P. (2007). “Probe Vehicle Runs or Loop Detectors? Effect of Detector Spacing and Sample Size on the Accuracy of Freeway Congestion Monitoring.” Compendium of Papers CD-ROM, 86th Transportation Research Board Annual Meeting, Washington, DC, January 21-24, 2007.
- Kwon, J., Varaiya, P., and Skabardonis, A. (2003). “Estimation of Truck Traffic Volume from Single Loop Detector Using Lane-to-lane Speed Correlation.” Compendium of Papers CD-ROM, 82nd Transportation Research Board Annual Meeting, Washington, DC, January 2003.
- Kerner, B. S., and Klenov, S. L. (2010). “Explanation of Complex Dynamics of Congested Traffic in NGSIM-Data with Three-Phase Traffic Theory.” Compendium of Papers CD-ROM, 89th Transportation Research Board Annual Meeting, Washington, DC, January 2010.
- Kerner, B. S. (2004). *The Physics of Traffic: Empirical Freeway Pattern Features, Engineering Applications, and Theory*. Springer, 2004.
- Kerner, B. S. (1998). “Experimental Features of Self-Organization in Traffic Flow.” *Physical Review Letters*, Volume 81, Number 17, October 1998.
- Kerner, B. S., and Konhäuser, P. (1994). “Structure and Parameters of Clusters in Traffic Flow.” *Physical Review E*, Volume 50, Number 1, July 1994.
- Koshi, M., Iwasaki, M. and Okhura, I. (1983). “Some findings and an overview on vehicular flow characteristics.” *Proceedings, 8th International Symposium on Transportation and Traffic Flow Theory* (Edited by Hurdle, V.F., Hauer, E. and Steuart, G.F.) University of Toronto Press, Toronto, Canada, pp. 403-426.
- Liu, X., and Danczyk, A. (2008). “Optimal Detector Placement for Freeway Bottleneck Identification.” Compendium of Papers CD-ROM, 87th Transportation Research Board Annual Meeting, Washington, DC, January 13-17, 2008.
- Lorenz, R. M., and Elefteriadou, L. (2001). “Defining Freeway Capacity as a Function of the Breakdown Probability.” Compendium of Papers CD-ROM, 80th Transportation

- Research Board Annual Meeting, Washington, DC, January 2001.
- Mirchandani, P. B., and He, Y. (2008). "Sensor Locations on a Network to Predict Travel Times." Compendium of Papers CD-ROM, 87th Transportation Research Board Annual Meeting, Washington, DC, January 13-17, 2008.
- May, A.D. (1990). *Traffic Flow Fundamentals*. Prentice-Hall. Englewood Cliffs, New Jersey.
- Neubert, L., Santen, L., Schadschneider, A., and Schreckenberg, M. (1999). "Single-vehicle Data of Highway Traffic: A Statistical Analysis." *Physical Review E*, Volume 60, Number 6, December 1999.
- Nihan, N. L., Wang, Y.H., and Cheevarunothai, P. (2006). *Improving Dual-Loop Truck (and Speed) Data: Quick Detection of Malfunctioning Loops and Calculation of Required Adjustments*. Research Report, TNW2006.
- Nihan, N. (1997). "Aid to Determining Freeway Metering Rates and Detecting Loop Errors." *Journal of Transportation Engineering*, Vol 123, No 6, ASCE, November/December 1997, pp. 454-458.
- Nihan, N. L., Zhang, X., and Wang, Y. (2002). *Evaluation of Dual-loop Data Accuracy Using Video Ground Truth Data*. Research Report, TNW2002.
- Ohio Department of Transportation (ODOT) (2007). *Research Development*. Cooperative research Seminar 2007. Crowne Plaza Columbus North, Columbus, Ohio. August 30, 2007.
- SpeedInfo, Inc. (2008). "Dayton, Ohio Drivers to Receive Real-time Traffic Information and Travel Times." Accessible at <http://www.speedinfo.com/04roads/roads-page01.html>.
- Texas Transportation Institute and Federal Highway Administration (1998). *Travel Time Data Collection Handbook*. Report No. FHWA-PL-98-035
- Turner, S., Albert, L., Gajewski, B., and Eisele, W. (2000). "Archived Intelligent Transportation System Data Quality: Preliminary Analysis of San Antonio Transguide Data", *Transportation Research Record: Journal of the Transportation Research Board*, No. 1719, TRB, National Research Council, Washington, D.C., pp. 77-84.
- Polus, A. and Pollatschek, M. (2002). "Stochastic Nature of Freeway Capacity and Its Estimation." *Canadian Journal of Civil Engineering*, 29, 2002, pp. 842-852.
- Vanajakshi, L. (2004). "Estimation and prediction of travel time from loop detector data for intelligent transportation systems applications." A Dissertation submitted to Texas A & M University.
- Viti, F., Verbeke, W., and Tampère, C. M. J. (2008). "Sensor Locations for Reliable Travel Time Prediction and Dynamic Management of Traffic Networks." *Compendium of Papers CD-ROM for the 87th Transportation Research Board Annual Meeting*, Washington, DC, January 13-17, 2008.
- Wei, H. (2008). Report on Characterize Dynamic Dilemma Zone and Minimize Its Effect at Signalized Intersections. Research report for

Ohio Transportation Consortium.

- Wei, H., Meyer, E., Lee, J. and Feng, C.E. (2005). "Video-Capture-Based Approach to Extract Multiple Vehicular Trajectory Data for Traffic Modeling," *ASCE Journal of Transportation Engineering* Volume 131, No. 7 (2005), pp. 496-505.
- Wieczorek, J., Fernández-Moctezuma, R. J., and Bertini, R. L. (2010). "Techniques for Validating an Automatic Bottleneck Detection Tool Using Archived Freeway Sensor Data." Compendium of Papers CD-ROM, 89th Transportation Research Board Annual Meeting, Washington, DC, January 2010.
- Zhang, X., Wang, Y., Nihan, N. L., and Hallenbeck, M. E. (2003). "Development of a System to Collect Loop Detector Event (Individual Vehicle) Data." *Transportation Research Record: Journal of the Transportation Research Board*, No. 1855, TRB, National Research Council, Washington, D.C., pp. 168-175.
- Zhang, Y., Ye, Z., and Xie, Y. (2008). "Estimation of Large Truck Volume Using Single Loop Detector Data." Compendium of Papers CD-ROM, 87th Transportation Research Board Annual Meeting, Washington, DC, January 2008.
- Zhu, W., Boriboonsomsin, K., and Barth, M. (2010) "Estimating Truck Traffic Speed from Single-loop Detector Data." *Compendium of Papers CD-ROM for the 89th Transportation Research Board Annual Meeting*, Washington, DC, 2010.